

Technical Requirements for Plumbing Works in Buildings

(April 2026 version)



Water Supplies Department

Table of Contents

Preface.....	1
Part A: Plumbing Installation Requirements	2
1. General.....	2
1.1 Definitions.....	2
1.2 Abbreviations.....	4
1.3 Commonly Used Waterworks Fittings.....	5
2. General Principles.....	7
2.1 General Principles for Installing Plumbing Works.....	7
3. Metering.....	8
3.1 General.....	8
3.2 Meter Position.....	10
3.2.1 General Requirements for Meter Positions	10
3.2.2 Architectural and Mechanical and Electrical (M&E) Requirements for Meter Room/Box/Cabinet/Chamber	11
3.2.3 Permanent Display Board showing Water Meter Details	13
3.2.4 Mounting Height of Water Meters in Meter Rooms/Boxes/Cabinets	13
3.2.5 Location of Water Meter at Construction Sites/ Sites for Short-Term Tenancy	14
3.2.6 Location of Water Meter at Landscape Areas	14
3.3 Master Meter and Check Meter	14
3.3.1 Purpose of Introducing Master Meter and Check Meter	14
3.3.2 Principles of Master Meters Provision	14
3.3.3 Principles of Sub-meters Provision for Buried Fresh Water Inside Service and Fire Service	15
3.3.4 Arrangements of Master Meter	15
3.3.5 Check Meter Requirements	17
3.4 Automatic Meter Reading (AMR) System	17
3.5 Separate Metering in Existing Premises	17
3.6 Installation of Separate Water Meters for Subdivided Units in Residential Premises ..	18
3.6.1 General Requirement.....	18
3.6.2 Application and Plumbing Requirements	18
3.6.3 Meter Position Requirement for Smart Water Meter.....	21
3.6.4 Meter Position Requirement for Mechanical Water Meter.....	21
4. Inside Service.....	23
4.1 Pipe & Fitting Materials.....	23
4.1.1 General	23
4.1.2 Requirements of Minimum Pipe Sizes	23

4.1.3 Modifications to Pipes	23
4.2 Fresh Water Supply.....	23
4.2.1 General Requirements	23
4.2.2 Supply Modes	24
4.2.3 Backflow/ Cross-connection Prevention	24
4.2.4 General Pipework Arrangement	28
4.2.7 Hot Water Systems	34
4.3 Flushing Water Supply	38
4.3.1 Sources of Flushing Water Supply	38
4.3.2 Pipe & Fitting Materials	38
4.3.3 Metering Requirements	38
4.3.4 Supply Modes	38
4.3.5 General Pipework Arrangement	39
4.4 Not Used.	40
4.5 Not Used.	40
5. Fire Service	41
5.1 General.....	41
5.2 Metering Requirement	41
5.3 Pipe & Fitting Materials.....	41
5.4 Supply Types and Arrangements	41
5.4.1 General	41
5.4.2 Sprinkler/ Drencher System	42
5.4.3 Fire Hydrant/ Hose Reel System	43
5.4.4 Street Fire Hydrant System	44
5.4.5 Fire Service Ring Mains	44
5.4.6 Not Used.	44
5.4.7 Not Used.	44
6. Water Cisterns, Water Pumps and Other Miscellaneous	45
6.1 General.....	45
6.2 Cold Water Cisterns (or Cold Water Tanks).....	45
6.2.1 Location	45
6.2.2 Material Requirements	46
6.2.3 Cover for Water Tanks	46
6.2.4 Installation Requirements for Inlet and Outlet Pipes	47
6.2.5 Size of Storage Cisterns for Flushing, Domestic and Trade/Commercial Water Uses	49
6.2.6 Other Requirements	52

6.3 Water Pumps.....	52
6.4 Not Used.	52
6.5 Pressure Reducing Valves.....	52
6.6 Stop Valves for Draw-off Points.....	53
6.7 Water Taps	53
6.7.2 Installation Requirements for Sanitary Fixtures Supplied by Water Taps	53
6.8 Domestic Appliances	54
6.8.1 Water Purifiers/ Filters	54
6.8.2 Washing Machines and Dishwashers	55
6.9 Not Used.	56
6.10 Flushing Apparatus	56
6.10.1 General Requirements	56
6.10.2 Flushing Cisterns	56
6.10.3 Flushing Valves (Flushometers)	58
6.11 Earthing.....	58
7. Water Conservation	59
7.1 General.....	59
7.2 Minimum Flow Requirements for Fittings and water-closet fittings in Inside Service	59
7.3 Water Efficiency Requirements for Fittings and water-closet fittings in Inside Service	59
7.4 Alternatives to Application of WELS Products.....	60
7.5 Exemption from the Water Efficiency Requirements.....	61
7.6 Not Used.	62
Part B: Plumbing Material Standards and Requirements	63
B1. Introduction	63
B2. Pipes and Fittings to be Used in Inside Service or Fire Service	63
B2.1. Products subject to Approval by the WA.....	63
B2.2 ‘General Acceptance*’ (‘GA*’) Scheme (Voluntary)	67
B2.3 Leaching Test for General Acceptance (GA) Application of Taps and Mixers - Alternative Route	69
B3. Review of Standards and Requirements.....	70
B4. General Conditions for All Pipes, Fittings and Components for Use in Inside Service ...	70
B5. Pipes and Pipe Fittings	72
B6. Valves.....	84
B7. Taps/Mixers.....	94
B8. Products covered by Water Efficiency Labelling Scheme (WELS)	99

B9. Other Materials..... 101

List of Figures

<u>Fig. No.</u>	<u>Figure Title</u>
-	List of Symbols (1 of 2)
-	List of Symbols (2 of 2)
Fig. 1	Not Used
Fig. 2	Not Used
Fig. 3	Typical Installation of a 15mm diameter Water Meter
Fig. 4	Meter Dimensions
Fig. 5	Direct/ Indirect Supply System
Fig. 6	Indirect Supply System
Fig. 6A	Schematic Diagram for Cleansing (Type I)
Fig. 6B	Not used
Fig. 6C	Schematic layout of Hydro-vent Re-circulation System (Sheet 1 of 2)
Fig. 6D	Schematic layout of Hydro-vent Re-circulation System (Sheet 2 of 2)
Fig. 6E	Not used
Fig. 7	Non-pressure Type Heater/Dispenser (Sheet 1 of 2)
Fig. 7A	Non-pressure Type Heater/Dispenser (Sheet 2 of 2)
Fig. 8	Cistern Type Water Heater
Fig. 9	Instantaneous Gas Water Heater

<u>Fig. No.</u>	<u>Figure Title</u>
Fig. 10	Layout of Unvented Electric Thermal Storage Type Water Heater
Fig. 11	Pressure Type Thermal Storage Water Heater
Fig. 12	Direct Centralized Hot Water System
Fig. 13	Indirect Centralized Hot Water System
Fig. 14	Salt Water Flushing Supply System
Fig. 15	Flushing Supply Storage Cistern - Mixed Supply
Fig. 16	Not Used.
Fig. 17	Layout Drawing for Improvised Sprinkler System
Fig. 18	Layout Drawing for Fire Hydrant/Hose Reel System
Fig. 19	Not Used.
Fig. 20	Not Used.
Fig. 21	Layout Drawing for Street Fire Hydrant System
Fig. 22	Schematic Layout of Pressure Reducing Valves
Fig. 23	Water Flower Beds Plumbing System
Fig. 24	Typical Configuration of Master Meter and Sub-meter Chambers in Multiple-block development
Fig. 25	Details of Sub-meter Chamber
Fig. 26	Revised Arrangement of Master Meter Room (Sheet 1 of 5)
Fig. 27	Revised Arrangement of Master Meter Room (Sheet 2 of 5)

<u>Fig. No.</u>	<u>Figure Title</u>
Fig. 28	Revised Arrangement of Master Meter Room (Sheet 3 of 5)
Fig. 29	Revised Arrangement of Master Meter Room (Sheet 4 of 5)
Fig. 30	Revised Arrangement of Master Meter Room (Sheet 5 of 5)
Fig. 31	Details of Master Meter Box and Cabinet
Fig. 32	Details of Sub-meter Box and Cabinet
Fig. 33	Not Used.
Fig. 34	Typical Schematic Plumbing Diagram (Food Business (Restaurant) / Kitchen)
Fig. 35	Suspension Notice of Fresh Water Supply/ Temporary Mains Water for Flushing
Fig. 36	Minimum Clearance of Water Meters
Fig. 37	Water Dispenser/Drinking Fountain Supplied by A Water Tank without Other Draw-off Point
Fig. 38	Water Dispenser/Drinking Fountain Supplied by A Water Tank with Other Draw-off Point
Fig. 39	Water Dispenser/Drinking Fountain Connected to Existing Inside Service (Use of Double Check Valve)
Fig. 40	Water Dispenser/Drinking Fountain Connected to Existing Inside Service (Use of Backflow Preventer)
Fig. 41	Door to Meter Room
Fig. 42	Types of Door Handle to be Adopted
Fig. 43	Details of Pressure Tapping Point
Fig. 44	Schematic Piping Diagram for Improvised Hose Reel System (Direct-feed type)

List of Appendix

<u>Appendix No.</u>	<u>Appendix Title</u>
Appendix 1A	Essential aspects of plumbing design in new buildings
Appendix 2	Standard plumbing drawings for subdivided unit (SDU)

Preface

Water Supplies Department (WSD) published two booklets in the past, viz. the Handbook on Plumbing Installation for Buildings and the Hong Kong Waterworks Standard Requirements for Plumbing Installation in Buildings. Together with the Waterworks Ordinance (Chapter 102) (WWO), the Waterworks Regulation (Chapter 102A) (WWR), and the WSD Circular Letters to Licensed Plumbers and Authorized Persons, they depict the technical requirements and practical guidelines to be adopted in the design and construction of inside service and fire service in local buildings. Over the years, practitioners need to cross reference among these documents when designing and constructing plumbing installations. These documents are now consolidated into this single document entitled ‘Technical Requirements for Plumbing Works in Buildings’ for easy reference.

All the clauses in this guidebook belongs to one of the followings:

1. Statutory requirements stipulated in the WWO/WWR
(**clauses marked with an asterisk [*]**)
2. Requirements of the Water Authority
(**clauses marked with a hashtag [#]**)

Compliance with these clauses are mandatory for relevant plumbing works to be approved by the Water Authority.

WSD would like to thank the stakeholders, industry practitioners and government departments who have given valuable comments to this document.

Part A: Plumbing Installation Requirements

1. General

1.1 Definitions

1.1.1 The definitions used in this Technical Requirements, which bear the same meanings as in WWO and WWR, are as follows:-

Agent	A person who is approved under Section 7 of Waterworks Ordinance as an agent of a communal service.
Authorized Person	An Authorized Person registered under the Buildings Ordinance.
Communal Service	That part of a fire service or inside service which is used in common by more than one consumer in the same premises.
Connection to the Main	The pipe between the main and the control valve which is nearest to the main and which regulates the flow of a supply from the main into a fire service or inside service, such control valve and all fittings between such control valve and the main.
Consumer	A person who is approved under Section 7 of Waterworks Ordinance as a consumer of a fire service or inside service.
Designated Person	A person who is a licensed plumber; a registered plumbing worker; a registered plumbing worker (provisional); a person who carries out specified plumbing works under the instruction and supervision of a licensed plumber or registered plumbing worker; or a public officer authorized by the Water Authority.
Direct Supply System	A plumbing system which conveys water directly from the government water mains to the point of usage without any transit water storage tanks.
‘End-of-line’ Fittings	Products or part of a product, installed within 250 mL draw-off of a drinking water delivery point as stated in AS/NZS 4020
Expansion Joint	A joint that absorbs axial displacement of pipework caused by changes in temperature, lateral displacement and angular displacement.
Fire Service	The pipes and fittings in premises, and any pipes and fittings between the premises and a connection to the main, which are used or are intended to be used for a supply solely for the purposes of fire fighting.
Fitting	Any apparatus, cistern, cock, equipment, machinery, material, tank, tap and valve; and any appliance or device other than a meter, which is installed or used in a fire service or inside service.
Indirect Supply System	A plumbing system which conveys water from the government water mains to the point of usage through a transit water storage tank.
‘In-line’ Fittings	Products installed in locations other than ‘End-of-line’ Fittings, such as pipes, pipe fittings and valves etc.
Inside Service	The pipes and fittings in premises, and any pipes and fittings between the premises and a connection to the main (other than the pipes and fittings forming part of a fire service) which are used or are intended to be used for the purposes of a supply.

Licensed Plumber	A person licensed under the Waterworks Ordinance to construct, install, maintain, alter, repair or remove fire services or inside services.
Main	Main includes a connection to the main and any pipe owned by the Government and maintained by the Water Authority for the purposes of a supply.
Meter	An appliance or device owned by the Government and maintained by the Water Authority for the purpose of measuring water consumption.
Minimum Flow Rate Q_1	Lowest flow rate at which the meter is to operate within the maximum permissible errors.
Overload Flow Rate Q_4	Highest flow rate at which the meter is to operate for a short period of time within the maximum permissible errors, while maintaining its metrological performance when it is subsequently operating within the rated operating conditions.
Permanent Flow Rate Q_3	Highest flow rate within the rated operating conditions at which the meter is to operate within the maximum permissible errors.
Premises	Any building or structure or any part thereof and any place in which there is a fire service, inside service or any part of the waterworks; or in which a fire service or inside service is intended to be constructed or installed.
Registered plumbing worker	A person whose name is entered in the Register as a registered plumbing worker for the trade division under the provision of Cap. 583 Construction Workers Registration Ordinance.
Strainer	A device that separates and removes solids suspended in fluids, protecting equipment from their harmful effects.
Transitional Flow Rate Q_2	Flow rate between the permanent flow rate and the minimum flow rate that divides the flow rate range into two zones, the upper flow rate zone and the lower flow rate zone, each characterized by its own maximum permissible errors.
Water Authority	The Director of Water Supplies
Waterworks	Any property occupied, used or maintained by the Water Authority for the purpose of water supply, including all water gathering grounds.

1.2 Abbreviations

1.2.1 Abbreviations used in this booklet are as follows:-

AMR	Automatic Meter Reading
BS	British Standards
BSI	British Standards Institution
CL	Circular Letter
DWS	Director of Water Supplies
EM	Electromagnetic
FSD	Fire Services Department
GI	Galvanized Steel
LP	Licensed Plumber
M&E	Mechanical and Electrical
PB	Polybutylene
PE	Polyethylene
PE-X	Crosslinked Polyethylene
PRV	Pressure Reducing Valve
PVC-C	Chlorinated Polyvinyl Chloride
PVC-U	Unplasticized Polyvinyl Chloride
TMF	Temporary Mains Fresh Water for Flushing
TR	Technical Requirements
VPLD	Vertical Plumbing Line Diagram(s)
WSD	Water Supplies Department
WA	Water Authority
WRAS	Water Regulations Advisory Scheme of the United Kingdom
WELS	Water Efficiency Labelling Scheme
WW	Waterworks
WWO	Waterworks Ordinance Cap. 102
WWR	Waterworks Regulations Cap. 102A

1.3 Commonly Used Waterworks Fittings

1.3.1 The functions of some commonly used waterworks fittings are described in Table 1.3.1 below:-

Table 1.3.1 Functions of commonly used waterworks fittings

Fitting	Function
Anti-vacuum Valve	a valve in a water service that opens to admit air if the pressure within the water service falls below atmospheric pressure.
Ball Valve	a valve that provides a straight-through passage for the flow of fluid and in which the passage can be closed by a ball type device.
Boiler	an enclosed vessel in which water is heated by the direct application of heat. For requirements regarding the use and operation of boilers, Chapter 56 Boilers and Pressure Vessels Ordinance shall be referred.
Butterfly Valve	a valve in which a disc is rotated about a diametric axis of a cylinder to vary the aperture. It is used where space is limited or more sophisticated control is required.
Calorifier	a storage vessel, not open to the atmosphere, in which a supply of water is heated. The vessel contains an element, such as a coil of pipe, through which is passed a supply of hot water or steam, in such a way that the two supplies do not mix, heat being transferred through the walls of the element.
Expansion Vessel	a closed vessel for accommodating the thermal expansion of water in a pressurized hot water heating system
Float Switch	a device incorporating a float that operates a switch in response to changes in the level of a liquid.
Float Operated Valve	a valve that controls the entry of water into a storage cistern or flushing cistern, closing off the supply when the water level in the cistern has reached a predetermined level. It is sometimes called a ball cock, ball float valve or float-operated valve.
Gate Valve	a valve that provides a straight-through passage for the flow of fluid and in which the passage can be closed by a gate. It is used on distribution pipework from a storage cistern. This valve is sometimes referred to as a fullway gate valve because when it is fully open, there is no restriction of flow through the valve.
Loose Jumper Type Stopcock	a screwdown pattern valve with horizontal inlet and outlet connections. It incorporates a loose jumper valve permitting flow in one direction only. In case the supply main is shut off and drained

Fitting	Function
	down for any reason, the ‘non-return’ action of the loose valve plate will stop any backflow from the service pipe.
Non-return Valve	a valve that prevents reversal of flow in the pipe of a water supply by means of the check mechanism, the valve being opened by the flow of water and closed by the action of the check mechanism when the flow ceases, or by back pressure. It is also known as check valve.
Pressure Reducing Valve	a valve that reduces the pressure of a fluid immediately downstream of its position in a pipeline to a preselected value or by a predetermined ratio.
Pressure Relief Valve	a self-acting valve that automatically opens to prevent a predetermined safe pressure being exceeded.
Temperature Relief Valve	a self-acting valve that automatically opens to prevent a predetermined safe temperature being exceeded.
Stop Valve	A valve that can shut off the water flow.

2. General Principles

2.1 General Principles for Installing Plumbing Works

- 2.1.1 A person who designs, constructs, installs, alters or removes any part of a plumbing installation shall adhere to the following general principles for installing plumbing works:-
- *(a) all pipes and fittings shall comply with the requirements of WWO and WWR;
 - *(b) all plumbing works, except those works of a minor nature, shall be carried out by a designated person;
 - #(c) communal service shall not run through individual premises;
 - #(d) plumbing installations shall be arranged to avoid water contamination, water quality deterioration, water leakage and to ensure proper metering for water consumption; and
 - #(e) inside service of individual consumer shall not pass through the premises of another consumer.
- *2.1.2 In accordance with WWO and WWR, fresh water is generally supplied for the six main purposes, namely domestic purpose; trade purpose; shipping purpose; construction purpose; flushing purpose; and firefighting purpose. The purpose for water supply shall generally be related to its usage by the occupants of the premises.
- 2.1.3 Not Used.
- #2.1.4 Appendix 1A summarizes the essential aspects of plumbing design in new buildings for the reference of plumbing designers/applicants. The details listed in Appendix 1A is considered essential and will always be checked during the vetting of a plumbing proposal by the WA. Nevertheless, this does not mean that the WA will not check other aspects of the plumbing proposal for compliance with statutory and other requirements.

3. Metering

3.1 General

3.1.1 Not Used.

*3.1.2 The size, number and siting of water meters will be determined by the WA and water meters will be provided by the WA. Water meters may be installed either by the WA, a LP, a registered plumbing worker or a registered plumbing worker (provisional).

#3.1.3 Meter position shall be provided by the Licensed Plumber (LP) (employed by the applicant) for meter installation. The type of the water meter will be determined by the WA. Recommended meter types are given in Table 3.1.3.1. All domestic units shall be separately metered.

Table 3.1.3.1 Details for water meters

Meter Size (mm)	Recommended Meter Type	Remarks
15 to 40	Rotary Piston	--
50	Single-jet	<ul style="list-style-type: none"> ● Good low flow performance ● Must be installed horizontally
	Ultrasonic	<ul style="list-style-type: none"> ● Good low flow performance ● Better high flow performance than single-jet meter
50, 80 and 100	Turbine (Woltmann)	<ul style="list-style-type: none"> ● Good high flow performance
50 and above	Electromagnetic	<ul style="list-style-type: none"> ● Good high flow performance ● Better low flow performance than turbine meter

#3.1.4 Meters shall be sited at a meter room/box/cabinet at convenient locations in accessible communal area for direct supply system. For indirect supply system, the meters shall be sited at a meter room/box/cabinet in accessible communal area at roof level or at other convenient locations.

#3.1.5 In case the meters are sited at roof level, and system pressure is lower than 15m, fullway gate valves shall be fitted before meter positions.

#3.1.6 For connections up to and including 40 mm diameter, a loose jumper type stopcock shall be provided and placed with spindle in the vertical position at each meter position on the inlet side of the meter where the meter is not sited at roof level and where the pressure is considered adequate.

- #3.1.7 For connections larger than 40 mm diameter, a gate valve shall be provided before the meter position and a non-return or check valve fitted on the delivery side as close as possible to the meter.
- #3.1.8 For water meter of nominal size of 50mm or above installed in direct supply system, a strainer shall be installed upstream of the meter.
- #3.1.9 Salt water supply will not be metered, but a meter position shall be provided for the purpose of periodic checking of consumption. It should be close to the lot boundary and connection to the Government mains or close to the point of connection from internal distribution mains whichever is applicable.
- #3.1.10 For salt water flushing supply, a stop valve shall be fitted at the inlet side of the meter position and a non-return or check valve shall be fitted on the delivery side as close as possible to the meter.
- #3.1.11 Minimum meter size requirement for business in categories as shown Table 3.1.11.1 shall be followed.

Table 3.1.11.1 Minimum Meter Size Requirement for Trade Fresh Water Supply to Designated Business Categories

Classification Code of business account categories	Minimum Size of Meter (mm)
SIC 641100 – Restaurants – Chinese	50
SIC 641998 – Restaurants – other eating places	25
SIC 641200 – Restaurants – non-Chinese	
SIC 641300 – Restaurants – fast food shops	
SIC 311100 – Slaughtering, preparing and preserving meat	
SIC 952000 – Laundries	

- #3.1.12 With an aim to prevent tampering of water meters, security seals shall be installed for all newly installed meters of size 40mm or above. ¹
- #3.1.13 Maximum size of master meter shall be limited to 300mm.

¹ Demonstration on installation of security seals are uploaded to the WSD webpage.
<https://www.wsd.gov.hk/en/plumbing-engineering/information-for-licensed-plumbers/demo-videos-on-installation-of-security-seals/index.html>

3.2 Meter Position

3.2.1 General Requirements for Meter Positions

- #3.2.1.1 The following practice should be adopted in plumbing work design for meter positions:-
- (a) fittings at meter position shall facilitate easy installation and removal of the water meter without the need to work on other pipes; and
 - (b) the fittings could be in the form of screw type connector, flange type adaptor or other types of suitable fittings, regardless of the size and type of water meter provided by the WA; and
 - (c) when sump and pump system is adopted and the meters are sited on convenient locations at roof level, the sump and pump system (including a sump tank and a roof storage tank) shall be fitted before meter positions.
- #3.2.1.2 The meter position for a 15mm diameter meter shall be constructed to include 20mm x 15mm bushes at both sides of the meter position with a clear effective length of 200mm distance piece of 15mm tube placed in between as shown in Fig 3. The tube shall be hollow with conspicuous holes drilled through the body. A long screw connector shall be provided immediately after the bush at the delivery side. The meter position for meter of all sizes shall also be similarly provided with corresponding fittings of appropriate sizes. Fig. 4 shall be referred for the length of the distance piece.
- #3.2.1.3 If a section of copper or stainless steel pipe is used either before or after a water meter position, the section of copper or stainless steel pipe between the water meter position and the first pipe clamp shall be jointed by screwed or flanged joints or soldering/brazing joint or press joint.
- #3.2.1.4 PVC-U fittings shall be used at the meter position if PVC-U materials are used as inside service. Brass/copper long screw (connector) shall be used at TMF position. Brass/copper fittings shall be used at the meter position if copper, lined galvanized steel or thermo-plastic materials are used as inside service.
- #3.2.1.5 Operational range and specifications for different type water meters currently adopted by WSD are given in Table 3.2.1.5.5.

Table 3.2.1.5.1 Not Used

Table 3.2.1.5.2 Not Used

Table 3.2.1.5.3 Not Used

Table 3.2.1.5.4 Not Used

Table 3.2.1.5.5 Operational range and specification of different type water meters

METER TYPE	SIZE (mm)	THE CLEAR LENGTH OF STRAIGHT PIPE LENGTH REQUIREMENT, WHERE D IS THE NOMINAL BORE OF THE WATER METER (mm)	
		UPSTREAM	DOWNSTREAM
SINGLE JET	50	5D	2D
	80		
	100		
TURBINE/WOLTMANN	50	5D	2D
	80		
	100		
	150		
	200		
	250		
	300		
ULTRASONIC	50	3D	2D
ELECTROMAGNETIC	50	3D	2D
	80		
	100		
	150		

3.2.2 Architectural and Mechanical and Electrical (M&E) Requirements for Meter Room/Box/Cabinet/Chamber

#3.2.2.1 All water meters, including vacant meter positions and check meter positions, shall be arranged in groups of more than one meter positions and housed in meter rooms / boxes / cabinet / chamber.

#3.2.2.2 The meter rooms/boxes/cabinets/chambers shall be designed solely for housing water meters to protect them against exposure to weather, falling objects and other undue external interferences and to facilitate reading and maintenance of water meters. When preparing VPLD submission, the applicant shall submit the layout and elevation plans of the meter rooms/boxes with dimensions, including the width and height of the entrances (door openings in case of meter boxes) for the WA’s approval.

#3.2.2.3 No other building services such as drainage systems, fire hoses, M&E installations (equipment, cables and ducting, etc.) shall pass through or be placed inside all water meter room / box / cabinet / chamber and check meter position except

lighting, ventilation, drainage, and smart metering if required by the WA etc., solely to facilitate meter reading and maintenance of water meters.

#3.2.2.4 The following architectural requirements as illustrated in Fig. 41 & 42 shall be met:-

- (a) for meter rooms, the minimum distance between the outward face of the meter group and the wall/door opening directly opposite the meter group shall be 1000mm and there shall be no obstacles in between. Besides, if the door to the meter room is to be opened at an inward position and it is at the opposite side of the meter group, the minimum perpendicular distance between the outward face of the meter group and the door (the point on the door that is nearest to the meter group) when it is fully opened shall be 600mm;
- (b) the clear width and height of the door entrance to the meter room shall not be less than 800 mm and 2000 mm respectively. The arrangement of the meter position(s) and the door opening of the meter box / cabinet shall be arranged in such a manner that staff of the WA would not be required to lean inwards to take meter readings or carry out maintenance works. For meter boxes / cabinets, the clear depth measured from the outside face shall not be more than 800mm;
- (c) an entrance located at communal area for safe, free, and uninterrupted access to the meter room/box/cabinet/chamber shall be provided;
- (d) if self-closing device is equipped on the door to the meter room/box/cabinet, a free egress lock shall be installed on the door to facilitate the personnel undertaking meter reading or maintenance to unlock the door from the inside. The lock of the door to the meter room shall be located at a level between 0.9m and 1.1m above the finished floor level. The door to the meter room shall be equipped with handle to facilitate door opening. The door handle shall be either in the form of long cylindrical or spherical shape to facilitate handling. Covered or flat sectioned handles shall not be used;
- (e) the outside of the door(s) to the meter room/box/cabinet shall be clearly marked 「水錶」, "Water Meters" in both Chinese and English of font size not less than 30mm for easy identification;
- (f) if there are more than one water meter room/box/cabinet inside a building block, master-key locks shall be used at all meter rooms/boxes/cabinets;
- (g) for village type buildings and similar, water meters shall be installed in meter room(s)/box(es)/cabinet(s) located at the boundary and shall be accessible from the public area; and
- (h) meter rooms/boxes/cabinets inside market/commercial complex shall be

positioned in areas with clear access and with no obstruction.

- #3.2.2.5 The following M&E requirements shall be met:-
- (a) when the meter room is occupied for taking meter readings and/or maintenance of water meters, the illumination shall not be less than 120 lux at meter positions and the mechanical ventilation shall not be less than 6 air-changes per hour; and
 - (b) provision of adequate drainage inside the meter room, the meter cabinet and the meter box positioned at floor level shall be made.
- #3.2.2.6 Standard configuration of meter box/ cabinet/ room for master meter, check meter, sub-meter and water meter for all new developments are shown in Fig. 31, Fig. 32, Fig. 36 and Fig. 41.
- #3.2.2.7 The minimum longitudinal working clearance between both ends of meter flange of water meter / check meter position and any obstruction should be 150 mm.

3.2.3 Permanent Display Board showing Water Meter Details

- #3.2.3.1 Upon completion of the water meter installation inside a meter room/box/cabinet, the LP shall install a permanent display board at the wall/door inside the meter room/box/cabinet showing the location and elevation of the meter positions. The top of the board shall not be higher than 1800 mm above the floor level and the bottom of the board shall not be lower than 500 mm for an individual meter above the floor level. This display board shall be constructed of durable plastic or corrosion-resistant plate engraved with words in block letters and diagrams in black on light colour background. The font size shall be of standardized font type and be not less than 18 points (i.e. 7 mm in height). Details of this display board shall be submitted by the applicant as part of the VPLD for the WA's approval. This requirement can be waived for small meter boxes accommodating 3 meters or less.

3.2.4 Mounting Height of Water Meters in Meter Rooms/Boxes/Cabinets

- #3.2.4.1 For meters arranged in groups, no meter position shall be lower than 300 mm nor higher than 1500 mm above the floor level. This requirement is also applicable for water meters installed inside meter boxes and cabinets. For projects where corridor meter arrangement is chosen and accepted, individual meter positions shall be at a suitable height not less than 750 mm but not more than 1500 mm above the floor level. Minimum clearance should be provided for water meters according to Fig. 36.

3.2.5 Location of Water Meter at Construction Sites/ Sites for Short-Term Tenancy

#3.2.5.1 The meter position of a supply to a construction site shall be provided within a meter room/box/cabinet located at the hoarding recess area so that reading and maintenance of the meter can be carried out outside the construction site.

#3.2.5.2 Safe, free and uninterrupted access to the meter room/box/cabinet should be provided and maintained at all time to ensure the safety of personnel undertaking meter reading or maintenance adjacent to construction activities. The door of the meter room/box/cabinet shall be made of 50mm x 50mm wire mesh. Details of the meter room or meter box are subject to the approval of the WA. Meter dials should be installed at the face of wire mesh for WA to conduct any necessary works related to water meter (e.g. to inspect the meter and take meter readings).

3.2.6 Location of Water Meter at Landscape Areas

#3.2.6.1 For a meter installed in a landscape area, it should be installed above ground level. In case the meter is installed in a meter box/cabinet, there shall be a proper working space in front of the meter box/cabinet with a clear working headroom not less than 2 meters.

#3.2.6.2 A safe pedestrian access to the meter position should be provided.

3.3 Master Meter and Check Meter

3.3.1 Purpose of Introducing Master Meter and Check Meter

3.3.1.1 Not Used.

3.3.2 Principles of Master Meters Provision

#3.3.2.1 Subject to Clause 3.3.2.3, master meter(s) shall be provided to fresh water and TMF inside service and fire service of all new developments with more than 1 building block, regardless of the total length of underground buried and concealed pipes.

#3.3.2.2 Subject to Clause 3.3.2.3, for single detached village type buildings and single block buildings, master meters will not be required but all pipework between the connection to the main and meter positions shall be exposed or laid in a proper service trench/duct, except that branch mains of less than one straight pipe length of 6 metres from tee-connection to a building block may be buried.

#3.3.2.3 Master meters shall be provided to fresh water and TMF inside service and fire service in all new government premises (including developments with no building

block and single block building), no matter the connecting water pipes are buried, exposed or laid in service trench (applicable to all new government premises with Form WWO 542 submitted to WSD on or after 1st January 2021).

3.3.3 Principles of Sub-meters Provision for Buried Fresh Water Inside Service and Fire Service

3.3.3.1 Not Used.

#3.3.3.2 Sub-meter chambers with check meter positions shall be provided at underground branch mains on a building-cluster basis except for developments with 5 or less building blocks of the same type only. Each building-cluster shall not include more than 5 building blocks of the same type in general. For typical configuration of master meter and sub-meter chambers in a multiple-block development, Fig. 24 shall be referred. For details of sub-meter chambers, Fig. 25 shall be referred.

#3.3.3.3 The installation of sub-meter chambers for TMF inside service are not required.

#3.3.3.4 Construction of a separate sub-meter chamber at a branch main is not required if:-
(i) the check meter room inside a building block is located less than one straight pipe length of 6m from the tee-connection; or
(ii) all the pipework between the tee-connection and the building block is exposed.

3.3.4 Arrangements of Master Meter

#3.3.4.1 One master meter shall be installed for each FW/TMF/FS inlet pipe supplying a development site at the lot boundary irrespective of the number of connection points to the government mains.

#3.3.4.2 The master meter room/cabinet/box shall be located at-grade where feasible. Otherwise, full justifications for non-compliance with such requirement shall be provided to the WA for consideration and approval.

#3.3.4.3 Standard master meter room/cabinet/box configuration for all new developments are shown in Figs. 26 to 31.

#3.3.4.4 In general, a minimum straight pipe lengths immediately upstream and downstream of a master meter or check meter shall be provided to ensure accuracy of master meters and check meters.

#3.3.4.5 The upstream and downstream straight pipe length requirements for different type

of meters shall not be less than the straight length requirement shown in Fig. 30.

- #3.3.4.6 Not Used.
- 3.3.4.7 Not Used.
- 3.3.4.8 Not Used.
- #3.3.4.9 Due to omission of by-pass pipe arrangement for inside service and fire service, master meters of diameter less than or equal to 100mm could be housed in a box or cabinet as shown in Fig. 31. A master meter room will be required for master meters larger than 100mm in diameter.
- #3.3.4.10 If the water main is to be laid underneath private roads which is scheduled to be handed over to government within 5 years after completion, master meters shall be installed for each FW/TMF/FS inlet pipe supplying each group of buildings/podia at their respective boundaries. On top of this, master meters are also required at the estate's boundary as illustrated in Fig. 24.
- #3.3.4.11 If the handover is scheduled beyond 5 years after completion, the said master meter positions mentioned in Clause 3.3.4.10 are still required, except the positions are temporarily bridged over by short pieces.
- #3.3.4.12 Fire service supply needs to be unaffected by potable supply interruption as far as practicable. Fire service needs to be separated from the potable supply right at the lot boundary.
- #3.3.4.13 Architectural and M&E requirements for the master meter room shall comply with the requirements in Sections 3.2.2.4 and 3.2.2.5. However, applicant may request for relaxation of the requirement with justifications and flexibility may be allowed at the discretion of the WA.
- #3.3.4.14 A strainer shall be installed upstream of all master meter.
- #3.3.4.15 For pressure monitoring, a pressure tapping point at the straight pipe after flange adapter to master meters of 50mm and above shall be provided as shown in Fig. 27, 28, 31 and 43. As an alternative, pressure tapping point provided on a flange ring after the straight pipe is also permitted. The connection details of pressure tapping

point installed by other methods shall be provided to the WA for consideration and approval.

3.3.5 Check Meter Requirements

#3.3.5.1 A check meter position shall be provided close to the end of the communal service supplying a building block for all fresh water and flushing water inside service and fire service.

#3.3.5.2 The check meter position shall be located at accessible communal areas for ease of meter reading and maintenance at all times.

#3.3.5.3 Not Used.

#3.3.5.4 Not Used.

3.4 Automatic Meter Reading (AMR) System

#3.4.1 If AMR is adopted in a development, the ‘Standard Requirements for the Supply and Installation of Automatic Meter Reading (AMR) Outstation’ posted in WSD website² shall be followed.

3.5 Separate Metering in Existing Premises

#3.5.1 The inside service shall be constructed from each flat to the existing common meter positions.

#3.5.2 In an occupied building, a temporary by-pass arrangement as close to the delivery side of the meter as possible shall be provided to maintain water supply to various units of accommodation when plumbing work is being carried out on separate meter conversion. The temporary arrangement shall be such that the consumption is still measured by the bulk meter. This by-pass arrangement must be removed immediately after the new separate meters are fixed. The bulk meter shall also be removed if no longer required.

#3.5.3 If part of an inside service is required to be retained as communal service, it is necessary to obtain an undertaking from the Developer/Owner, Management Committee, Landlords Association, Residents Association, Incorporated Owners,

² <http://www.wsd.gov.hk/en/plumbing-engineering/automatic-meter-reading/index.html>

Mutual Aid Committee or an individual resident flat owner to accept responsibility for the common inside service from the connection to the main. If there is no consent for using the existing common inside service, a new connection is required for the conversion of some existing premises from a communal meter to separate meters and the new separate inside services become the responsibility of individual consumers.

3.6 Installation of Separate Water Meters for Subdivided Units in Residential Premises

3.6.1 General Requirement

#3.6.1.1 A separate water meter shall be installed for each subdivided unit (SDU) for recognition as Basic Housing Unit (BHU), where the SDUs concerned shall be in a flat in domestic building or domestic portion of composite building and there are separate plumbing systems for individual SDUs.

#3.6.1.2 Under prevailing technical requirements, salt water or temporary flushing main (TMF) approved by the WA shall be used for flushing purpose. A control valve shall be installed before each flushing cistern.

#3.6.1.3 If for valid technical reasons, the applicant is unable to provide or restore the requirement of using salt water from the main building or TMF approved by the WA for flushing purpose for the respective SDU, the applicant may apply to WA for using fresh water for flushing in lieu. Such an application will be considered and approved on a case-by-case basis and the fresh water supply for flushing in this regards shall be installed with a flushing meter and branched off before all separate water meters. A double check valve shall be provided for each branch of the fresh water flushing system and a control valve shall be installed before each flushing cistern.

3.6.2 Application and Plumbing Requirements

#3.6.2.1 SDUs requiring installation of separate water meters and other plumbing works³, viz. Scenario (A), shall follow the procedures and requirements stipulated below:

- (i) The applicant should appoint a responsible licensed plumber (RLP) to submit WWO 542 with a plumbing proposal with notification to the Water Authority (WA) to join the self-certification. The proposed plumbing works shall follow standard plumbing drawings for SDUs (see FIG. SDU-SPD01-06 in

³ Except plumbing works of a minor nature.

Appendix 2). The proposed plumbing works shall not include any concealed pipe while at least one control valve shall be installed for and as close to each SDU, which should be easily accessible. The RLP shall clearly demarcate the existing plumbing system and the proposed plumbing works to be carried out by him/her in the plumbing proposal.

- (ii) The WA will reply to the applicant to approve/comment on the application within 2 weeks of receipt.
- (iii) The RLP should submit WWO 46A Part I and Part II to the WA for approval before commencement of the plumbing works.
- (iv) WWO 1149 may not be required to be submitted along with WWO 46A Part I and Part II, but the RLP should undertake that the pipes and fittings to be installed are with General Acceptance (GA) and in accordance with the Waterworks Ordinance (WWO)/Waterworks Regulations (WWR) and the WA's requirements.
- (v) The WA will issue WWO 46A Part III with the approved drawings marked with water sampling point(s) and location(s) for non-destructive tests on lead content at solder joints, or reply with comments.
- (vi) Upon completion of plumbing works, the RLP should submit WWO 46A Part IV with supporting documents⁴, and WWO 1156A⁵ duly signed by the applicant, to apply for installation of separate water meters and double check valves and flushing meter for flushing facilities using fresh water (if applicable). The RLP shall clearly demarcate the existing plumbing system and the plumbing works covered by the above WWO 46A part IV in the as-built drawings.
- (vii) The WA will check whether all the required documents are submitted and in order. Upon receipt of satisfactory result of water sampling tests, the WA will issue WWO 46A Part V to effect water supply without final inspection

⁴ Supporting documents include:

- (a) Completion certificate;
- (b) As-built drawings;
- (c) As-built WWO 1149A;
- (d) Inspection checklist;
- (e) Self-certification of meter positions and associated works; and
- (f) Written request to accredited laboratory for water sampling test

⁵ WWO 1156A can also be submitted together with WWO 46A Part I & Part II.

and approval letter to WWO 1156A within 2 weeks from the receipt of WWO 46A Part IV, and the RLP will then arrange to collect separate water meters (either mechanical or smart type) from WSD.

- (viii) The RLP should submit completed meter installation table (MIT), completion photos, and self-certification of satisfactory completion of meter arrangement check (MAC), installation of double check valve (if applicable) and no water point other than that for flushing (if applicable) before the meter position of separate water meters. The WA may conduct audit check on the MAC and MIT before processing account for each meter.
- (ix) WSD will issue a certificate to the applicant to certify completion of installation of separate water meters for SDUs within 2 weeks.

#3.6.2.2 Existing SDUs requiring plumbing works only includes installation of separate water meters⁶, viz. Scenario (B), shall comply with the following requirements:

- (i) The applicant should notify the WA to join self-certification.
- (ii) The RLP should submit completion certification of meter positions and associated works and WWO 1156A duly signed by the applicant to apply for installation of separate water meters and double check valves for flushing facilities using fresh water (if applicable).
- (iii) The RLP shall clearly demarcate the existing plumbing system and the proposed plumbing works to be carried out by him/her in the plumbing proposal.
- (iv) The WA will issue approval letter to WWO 1156A within 2 weeks, and the RLP will collect separate water meters (either mechanical or smart type from WSD).
- (v) The RLP should submit completed MIT, completion photos, and self-certification of satisfactory completion of MAC, installation of double check valve (if applicable) and no water point other than that for flushing (if applicable) before the meter position of separate water meters. The WA may conduct audit check on the MAC and MIT before processing account for each

⁶ And other plumbing works of a minor nature.

meter.

- (vi) WSD will issue a certificate to the applicant to certify completion of installation of separate water meters for SDUs within 2 weeks.

#3.6.2.3 Participation in the above self-certification approach is on a voluntary basis. If the applicant chooses not to join the Scheme, the application workflow will remain unchanged and the RLP will not be required to certify the plumbing works, meter position and associated works whereas the WA will conduct site inspection following the prevailing procedures.

3.6.3 Meter Position Requirement for Smart Water Meter

- #3.6.3.1 The meter position requirements stipulated in Section 3.2 are not applicable.
- #3.6.3.2 Sufficient working space shall be allowed at meter positions for installation and maintenance of separate water meters.
- #3.6.3.3 The smart meters can be installed within a corridor in the shared part of the flat housing SDUs. If they are proposed to be installed inside individual SDUs, separate application with justifications should be submitted to seek the WA's approval.
- #3.6.3.4 For meters installed in a corridor in the shared part of the flat housing of the SDUs, the minimum clear width and height of the corridor as stipulated in the Code of Practice on the Minimum Standards of Living Conditions under Basic Housing Units Regulatory Regime shall be maintained.
- #3.6.3.5 The RLP shall verify the 4G signal strength at the meter positions and record in Annex to WWO 1156A.
- #3.6.3.6 A control valve shall be provided at meter position and before each separate water meter.

3.6.4 Meter Position Requirement for Mechanical Water Meter

- #3.6.4.1 The mechanical water meters shall be installed in a corridor in the shared part of the flat housing SDUs, or at the common parts of the corresponding building.
- #3.6.4.2 All separate water meters, shall be arranged in groups and installed as close to the door to the premise as practicable. No meter shall be installed at a position lower than 300 mm nor higher than 1,500 mm above the floor level. Minimum clearance should be provided for water meters according to Fig. 36.
- #3.6.4.3 For meters installed in a corridor in the shared part of the flat housing of the SDUs, the minimum clear width and height of the corridor as stipulated in the Code of Practice on the Minimum Standards of Living Conditions under Basic Housing Units Regulatory Regime shall be maintained.

- #3.6.4.4 Fittings at meter position shall facilitate easy installation and removal of the water meter without the need to work on other pipes.
- #3.6.4.5 A control valve shall be provided at meter position and before each separate water meter.

4. Inside Service

4.1 Pipe & Fitting Materials

4.1.1 General

- #4.1.1.1 Pipes and fittings shall conform to the relevant standards as listed in Part B of this Technical Requirements and the WWR.
- #4.1.1.2 All plumbing works using soldering for connecting copper pipes shall require prior permission of the WA.
- #4.1.1.3 Plumbing designers should, as far as practicable, avoid using pipes of same size and same material for potable and non-potable water (including cleansing, irrigation, fire service, flushing etc.) at the same location in order to avoid misconnection of potable water to non-potable supplies. If pipes of same size and same material cannot be avoided at the same location, pipe identification marking (such as colour code, trade, destination, direction of flow or classification code) shall be provided for identification purpose.
- #4.1.1.4 A boundary valve should be installed in inside service within the lot boundary as close to the Government water supply connection as possible.

4.1.2 Requirements of Minimum Pipe Sizes

- *4.1.2.1 A pipe must not be less than 20mm in diameter, except that a branch pipe may be of 15mm or more in diameter if its length is not longer than 3m and it supplies only 1 draw-off point.

4.1.3 Modifications to Pipes

- *4.1.3.1 A bend or curve must not be made in any pipe so as to diminish the waterway or alter the internal diameter of the pipe.

4.2 Fresh Water Supply

4.2.1 General Requirements

- *4.2.1.1 All fresh water supplies to inside service, including TMF, shall be metered.
- #4.2.1.2 All domestic supplies and concessionary supplies shall be separately metered. For different applications of concessionary supplies, Section 4.2.5 shall be referred.
- 4.2.1.3 Not Used.

4.2.1.4 Not Used.

#4.2.1.5 Design of fresh water supply system shall comply with relevant requirements stipulated in the prevailing “Code of Practice for Prevention of Legionnaires’ Disease” published by Prevention of Legionnaires’ Disease Committee.

4.2.2 Supply Modes

#4.2.2.1 Fresh water supply to buildings with an overall height⁷ of less than or equal to 12m can be effected in one of the two following ways:-

- (a) direct supply system as illustrated in Fig. 5; or
- (b) indirect supply system, with a storage tank, a sump-and-pump system or a hydro-pneumatic pump system as illustrated in Fig. 5 and Fig. 6.

#4.2.2.2 Fresh water supply to buildings with an overall height of more than 12m shall be supplied by indirect supply systems as illustrated in Fig. 6 (i.e. a sump and pump system or a hydro-pneumatic pump system) or any equivalent system as approved by the WA for all floors. [This clause is applicable to new applications with Form WWO 542 submitted on or after 1 January 2019 except for those applications which have Form WWO 132 submitted before 1 September 2018.]

#4.2.2.3 The minimum residual pressure for fresh water would be 15 to 20 meter head measured at the connection to the main. The fresh supply inside service should be designed to the minimum available residual pressure as advised by the WA.

4.2.3 Backflow/ Cross-connection Prevention

4.2.3.1 Protection of Water Supplies

#4.2.3.1.1 All water supply systems shall be designed, installed, and maintained in order to prevent contaminants from being introduced into the fresh water supply systems.

#4.2.3.1.2 No device or system that may cause contamination of a water supply shall be connected directly or indirectly to any part of an inside service without appropriate cross-connection prevention or backflow prevention control suitable for the level of hazard.

4.2.3.1.3 Not Used.

⁷ The meaning of the height of building is similar to that defined under the Buildings Ordinance (Application to the New Territories) Ordinance, Chapter 121. For more detailed illustration, Appendix I to III of the ‘Building New Territories Exempted Houses’ published by the Lands Department (available in http://www.landsd.gov.hk/en/images/doc/Building_NT_Exempted_Houses_e.pdf) could be referred.

4.2.3.2 Not Used.

4.2.3.3 Provision of Backflow Prevention Devices

#4.2.3.3.1 The fresh water supply shall be protected by installing appropriate backflow prevention device to prevent cross connection and/or risk of backflow contamination. A list of common backflow prevention devices is shown in Table 4.2.3.7.1 for reference. Requirements on backflow prevention device for some typical installations are listed in Table 4.2.3.7.2. For other installations, the backflow prevention devices shall be provided based on the fluid category applicable to the installations according to BS EN 1717.

#4.2.3.3.2 Backflow prevention devices shall comply with the latest BS EN 1717 and all relevant standard(s) for the devices.

4.2.3.4 Water Downstream of Backflow Prevention Device

#4.2.3.4.1 Piping conveying water downstream of backflow prevention device with corresponding fluid category equal to 3, 4 or 5 as in BS EN 1717, shall be clearly and permanently labelled 'WARNING! NOT FOR DRINKING' at every outlet.

4.2.3.5 Commissioning and Maintenance

#4.2.3.5.1 Backflow prevention devices shall be commissioned and tested after installation and prior to service. The devices shall be maintained in working order and tested for operational function at intervals not exceeding 12 months.

#4.2.3.5.2 If backflow prevention devices such as backflow preventer with reduced pressure zone device, is proposed to be used, they shall only be used with a maintenance program. If such program is unavailable, the backflow prevention devices shall not be fitted and break tank shall be provided.

4.2.3.6 Backflow Prevention Devices in Hot Water Systems

#4.2.3.6.1 The requirements of this section for backflow prevention devices shall apply equally to hot water systems and cold water inside services. The backflow prevention device used in hot water systems shall be suitable for the specific hot water installation.

4.2.3.7 Backflow Prevention Devices Requirement for Applications

#4.2.3.7.1 Tables 4.2.3.7.1 and 4.2.3.7.2 shall be referred to for commonly used backflow prevention devices and the requirement on backflow prevention device for typical installations respectively. For concessionary water supplies, Clause 4.2.5.2 shall be

referred.

Table 4.2.3.7.1 Properties of common backflow prevention devices

Backflow prevention device	Corresponding Fluid category as in BS EN 1717:2000	Protection against back-pressure	Protection against back-syphonage
Break tank	1-5	Yes	Yes
Backflow preventer with Reduced Pressure Zone (RPZ) Device	1-4	Yes	Yes
Check valve/ Non-return valve	1-2	Yes	Yes
Double check valve*	1-2	Yes	Yes
Anti-vacuum valve	1-2	No	Yes

* For meters used in systematic flushing in village houses as in Section 5.2 of 'Guide to Application for Water Supply'.

Table 4.2.3.7.2 Requirement on backflow prevention device for typical installations

Installations	Requirement on backflow prevention device
Irrigation systems without insecticide or fertilizer application: (i) Domestic or commercial irrigation system with fixed sprinkler heads or outlets not less than 150mm above ground level (Note 1); (ii) Mini-irrigation systems such as pop-up sprinklers or permeable hoses or with sprinkler heads less than 150mm above ground level (Note 2)	Backflow preventer or Reduced Pressure Zone (RPZ) Device
Commercial agricultural systems: (i) Commercial irrigation outlets below or at ground level and/or permeable pipes, with or without chemical additives; (ii) Insecticide or fertilizer applications; or (iii) Commercial hydroponic systems.	Break Tank
Garden served by point supply, nurseries, large landscaped areas or sports fields	Break Tank (Note 8)
Kitchen equipment for non-domestic use	Details please refer to FIG. 34 under TR
Fixtures for general ablution (e.g. basin, showers) with submerged inlets or with points of discharge below the overflow level	Details please refer to Note 4
Commercial laundries	Details please refer to FIG. 34 under TR
Industrial processes	Break Tank or Backflow preventer or Reduced Pressure Zone (RPZ) Device
Cooling towers	Break Tank
Water misting system	Anti-vacuum valve and non-return valve (Note 9)
Fire service	Details please refer to Note 5
Fire service (improvised hose reel system)	Details please refer to FIG. 44 under TR
Fire service (improvised sprinkler system)	Details please refer to FIG. 17 under TR
Drinking Fountains (not located at street side)	Details please refer to FIG. 37 to 39 under TR
Drinking Fountains (located at street side)	Details please refer to FIG. 40 under TR
Smart water closets	Break Tank or equivalent

Note 1: Examples include systems with manual irrigation points.

Note 2: Examples include systems with drip-feed pipes.

Note 3: Schematic layout of the hydro-vent re-circulation system can be referred to FIG 6C and 6D.

Note 4: The water supply to the fixtures should be provided by either a cistern supplying water to such fixture only or a hot water distribution system supplying such fixture only.

Note 5: A fire services water tank is always required for conventional fire service supply system and a physical break is therefore provided.

Note 6: Schematic layout can be referred to FIG. 37 to 39. Double check valve should be used in direct supply system.

Note 7: Schematic layout can be referred to FIG. 40.

Note 8: For concessionary supplies, when the installation takes the form of supply standpipe and that hosepipe will only be connected to the draw-off point when water is drawn, an anti-vacuum valve and a non-return valve may be installed at the draw-off point in lieu of a break tank for preventing back syphonage because the potential hazard of water contamination is relatively low.

Note 9: For water misting system operated with pumps, a break tank should be installed instead of an anti-vacuum valve and a non-return valve.

4.2.4 General Pipework Arrangement

#4.2.4.1 All plumbing works between the lot boundary and any master meter or check meter positions shall be exposed or laid in a proper service trench/duct to facilitate inspection and repairs. Adequate drainage shall be provided to remove water inside the trench/duct.

#4.2.4.2 If the connection is not laid in an exposed manner at the lot boundary, then it shall be laid inside underground service trench/duct with adequate cover. The underground/buried water mains should be laid with cover according to the latest required minimum depth of services and associated installations stipulated by Highways Department. The current minimum cover requirements stated in the Conditions of Excavation Permit are 450mm and 900mm on non-carriageway and carriageway respectively.

#4.2.4.3 No water pipe shall be embedded within load bearing structural elements in longitudinal direction. Such structural elements include, but not limited to, columns, beams and slabs. Screeding above slabs should not be considered as structural elements. Hence, water pipe embedded in screeding is acceptable. The water pipe in screeding shall be considered as embedded pipes.

#4.2.4.4 Vertical water pipes piercing through structural slabs and transfer plates; and horizontal water pipes piercing through beams, columns and structural walls shall be protected by sleeving or other suitable means.

#4.2.4.5 A tee-branch valve, i.e. an isolation valve at a branch pipe, shall be provided for all underground water pipes, and for all communal inside service, and shall be located close to the main pipe. This requirement is applicable to both cold and hot water systems.

- #4.2.4.6 Sufficient cleansing taps shall be provided at each floor of car parks of a building for car/floor washing. The cleansing supply at the car park shall be given from a fresh water cistern with a separate meter unless it is a part of the cleansing supply system of the building. Schematic layouts are shown in Fig 6A for reference.
- #4.2.4.7 No draw-off point in inside services shall be subject to a pressure of 6 bar or above.
- #4.2.4.8 The inside service shall be constructed from each flat to the existing common meter connection or in such other locations as determined by the WA.
- #4.2.4.9 For new sump and pump systems, a standby pumpset shall be provided.
- #4.2.4.10 For existing sump and pump systems, a standby pumpset shall be provided unless this proves to be impracticable.

4.2.5 Concessionary Usage of Mains Water

- #4.2.5.1 Approval to use government water supply for the purposes listed in Clause 4.2.5.2 can normally be given on concessionary basis when the territory is on full supply, subject to adequacy of the local water supply and distribution system. Such approval will be withdrawn if in the opinion of the WA the supply situation requires it.
- #4.2.5.2 The concessionary usages and requirements on mode of supply are summarized in Table 4.2.5.2.1. Permissions for such supplies shall be given by WSD.

Table 4.2.5.2.1 Minimum requirements on mode of supply for concessionary usage of mains water

Concessionary Usage	Off-Tank Supply	Mains Supply ^{1,2}	Notes
A. Amenities			
1. Swimming pools	✓		- Initial and annual filling - Make-up supply
2. Model boat pools	✓		- Initial filling - Refilling (once per 2 months in summer; once per 3 months in winter)
3. Water features	✓		- Initial filling - Make-up supply - Full re-circulation of water

Table 4.2.5.2.1 Minimum requirements on mode of supply for concessionary usage of mains water

Concessionary Usage	Off-Tank Supply	Mains Supply ^{1,2}	Notes
4. Artificial lakes	✓		- Initial filling - Make-up supply
B. Irrigation			
1. Gardens			
- served by point supply		✓	- For watering plants in public and private developments - Aggregate planting areas not less than 30m ² for both point and drip feed supply - Each water point to be served by a 20 metre-long hose - Number of water points shall be minimized - Water points to be numbered or adequately referenced - Sectional valves shall be provided for extensive systems - See Fig. 23 as reference
- served by 'drip feed' supply	✓		- For watering plants in public and private developments - Aggregate planting areas not less than 30m ² for both point and drip feed supply - Only one connection point would be given, unless:- • Extension of drip-feed not feasible due to physical barriers; and • Distance between two successive connection points exceeds 40 metres
2. Nurseries		✓	- For watering plants
3. Large landscape areas	✓		- For landscape areas in new towns
4. Sports fields		✓	- For tennis courts, bowling greens, cricket pitches and football pitches - Supply may be granted only if no practical alternative ³
5. Planter at footbridges, flyovers and roadways ⁴		✓	- For watering plants - Requirements for Gardens shall be fulfilled - Dedicated water points should not be used when a safe working environment cannot be provided to the maintenance personnel carrying out watering work ⁵

Table 4.2.5.2.1 Minimum requirements on mode of supply for concessionary usage of mains water

Concessionary Usage	Off-Tank Supply	Mains Supply ^{1,2}	Notes
C. Cleansing			
1. Buildings	✓		<ul style="list-style-type: none"> - Internal cleansing in buildings and open areas within lot boundary - For washing down floors and staircases, refuse chutes and lifts in large blocks of flats and offices; or - For essential floor cleansing in factories, hawker bazaars, markets, abattoirs and public latrines
2. Garages and car parks	✓		<ul style="list-style-type: none"> - For car-washing only
3. Transports	✓		<ul style="list-style-type: none"> - For washing down buses, railway rolling stocks, aircrafts and cargo containers - At depots and/or relevant facilities
4. Government refuse vehicles, bins and handcarts	✓		<ul style="list-style-type: none"> - At refuse collections points and/or relevant facilities etc.
5. Washing vehicles	✓		<ul style="list-style-type: none"> - For vehicles such as mechanical street-cleaners owned by the Government
6. Air pollution control	✓		<ul style="list-style-type: none"> - Concerning smoke or gas emitted from plants or equipment - Water loss due to evaporation only - Example includes hydro-vent system for kitchen
7. Dust suppression	✓		<ul style="list-style-type: none"> - Essential to industrial process or air pollution control - Re-circulation of water is required unless it is proved to be impracticable
D. Others			
1. Water damping facilities for high rise buildings	✓		<ul style="list-style-type: none"> - Initial filling - Subsequent refilling - Make-up supply
2. <u>Water misting system</u>	✓	✓ ⁶	<ul style="list-style-type: none"> - <u>For outdoor cooling</u> - <u>Can be branched off from an existing concessionary supply</u>

¹ An anti-vacuum valve and a non-return valve shall be installed at each draw-off point.

² The draw-off point takes the form of supply standpipe. A hose will only be connected to the draw-off point when water is drawn.

³ If there is practical alternative but the private source is not adequate and requires mains water supply

for augmentation to meet the demand, application should be referred to the DWS for approval.

⁴ For irrigating the plants on footbridges and flyovers, the supply point with a water meter will be provided normally at the pedestrian pavement under or near the footbridge/flyover. The project department/user department or its agent is to extend the water mains from the supply point to the greening areas/planter boxes on the footbridge/flyover.

⁵ For the safety of maintenance personnel the use of water wagons is preferred for the provision of water for watering the greening area/planter boxes/waterworks at the central median of a roadway. If water wagons cannot be used, supply points with water meters will be given at locations that staff of WSD can access the water meter readily and safely. If the water meter is installed at the ground level of the nearby pedestrian pavement, the project department/user department or its agent is to extend the water mains across the road to the central median.

⁶ Only applicable to system operating without pumps.

#4.2.5.3 An anti-vacuum valve and a non-return valve should be installed at the draw-off point in lieu of a water storage tank for preventing back syphonage when the potential hazard of water contamination is relatively low. 'Section B Irrigation' of Table 4.2.5.2.1 shall be referred for relevant usages.

#4.2.5.4 Draw-off tap that is freely accessible by the general public should be kept in an external protective box with lock and key.

#4.2.5.4a If an automatic irrigation system is used, off-tank supply is required.

#4.2.5.5 Installation of water points for internal cleansing of open yards and for other miscellaneous domestic purposes in private houses of bungalow type or the like can be permitted as part of the domestic supply. This will not be taken as a concessionary supply. It is not necessary to install any receptacle for this type of water points.

4.2.6 Metered Supply for Other Purposes

4.2.6.1 Supply for Construction Site

4.2.6.1.1 Not Used.

4.2.6.1.2 Not Used.

4.2.6.2 Supply for Temporary Structures and Modified/ Converted Structures

#4.2.6.2.1 Metered supply will be given to temporary structures and modified/converted structures, provided that:-

- (a) The water supply is adequate and available in the proximity;
- (b) The inside services are designed and constructed properly, such that the requirements under WWO are satisfied; and

- (c) The consumer/agent gives an undertaking to pay and accept the responsibility for the custody and maintenance of the inside service.

#4.2.6.2.2 The premises shall have separate access, proper drainage system and bear a proper postal address.

4.2.6.3 Water Supply for Cooling / Air-conditioning / Humidification Purposes

*4.2.6.3.1 Water supply shall not be used for any heating, cooling or humidification purposes except with the approval of the WA.

#4.2.6.3.2 Either fresh or salt mains water supply may be given for cooling / air-conditioning / humidification purposes if the system designed belongs to one of the following categories:-

- (a) Closed circuit cooling systems designed for any purpose where operational losses are negligible and no water is rejected to waste;
- (b) Cooling systems designed to have no evaporative losses, while all the water is re-used after cooling for an industrial process; (The water consumption required for normal trade must not be less than that required for air-conditioning/ cooling purposes at peak cooling load);
- (c) Evaporative cooling systems designed for an essential industrial process for cooling or air-conditioning purposes, provided that system losses arise from evaporation, drift and bleed-off only;
- (d) Evaporative cooling/ air-conditioning/ humidification systems designed for essential purposes other than industrial processes, provided that system water losses arise from evaporation, drift and bleed-off only; or
- (e) Humidification system designed for essential industrial processes, e.g. the spraying of a fine mist in textile weaving plants.

#4.2.6.3.3 The application of mains water in evaporative type plants for purposes other than industrial process is limited to those cases where the cooling / air-conditioning / humidification system(s) is/ are critical for normal operation. The type of evaporative plant used should be of an enclosed design, so that wastage of water due to splashing is prevented. Examples are as follows:-

- (a) Air-conditioning system serving hospital areas where air-conditioning is essential for operation requirement, such as operating theatres, intensive care units and mortuaries etc.;
- (b) Cooling system for cold storage purpose or laboratory testing; or

- (c) Air-conditioning/ humidification system for major computer facilities, art galleries or testing laboratories.
- (d) Air-conditioning/ humidification system designed to achieve higher energy efficiency performance.

#4.2.6.3.4 Prior to the installation of the fresh water cooling towers (FWCT), applicants should apply for participation in the ‘Fresh Water Cooling Towers Scheme’ (FWCT Scheme) for air-conditioning systems administered by the Electrical and Mechanical Services Department (EMSD). The participation in the FWCT Scheme should comply with the requirements stipulated in the ‘Code of Practice for Fresh Water Cooling Towers’ promulgated by EMSD and the requirements of WSD. For details of the FWCT Scheme and all relevant requirements, EMSD’s website⁸ and WSD’s website⁹ shall be referred.

4.2.7 Hot Water Systems

4.2.7.1 Non-Centralized Hot Water System

- *4.2.7.1.1 When the factory test pressure of the heater is at least 1.5 times the maximum static pressure at the mains water supply point, non-pressure type heaters, cistern type water heaters, unvented electric thermal storage water heaters satisfying the requirements stipulated in Clauses 4.2.7.1.12 and instantaneous water heaters are permitted to be connected direct to the supply pipe without the necessity of providing storage.
- *4.2.7.1.2 When the factory test pressure of the heater is less than 1.5 times the maximum static water pressure at the mains water supply point then, for premises on direct supply, a water heater must be supplied with water from a cold water cistern.
- #4.2.7.1.3 A separate mains water storage cistern of 45 litres capacity shall be provided for each flat to supply such hot water apparatus in Clause 4.2.7.1.2.
- *4.2.7.1.4 Pressure type thermal storage heaters other than unvented electric thermal storage water heaters satisfying the requirements stipulated in Clauses 4.2.7.1.12 shall be supplied from storage cisterns no matter what the pressure at inlet point should be, except these are installed in flats supplied through the indirect or sump and pump system.

⁸ <http://www.emsd.gov.hk/>

⁹ <https://www.wsd.gov.hk/en/plumbing-engineering/information-for-licensed-plumbers/do-not-install-unauthorised-fresh-water-cooling-to/index.html>

- #4.2.7.1.5 For premises on direct supply, a separate mains water storage cistern of 45 litres capacity shall be provided for each flat to supply such hot water apparatus in Clause 4.2.7.1.4.
- #4.2.7.1.6 For flats supplied from the roof storage cistern of an indirect or sump and pump system, no separate storage for hot water apparatus will be required but the supply to the apparatus shall be by a separate down feed supplying the apparatus only unless the arrangement in Clause 4.2.7.1.7 is applied.
- #4.2.7.1.7 If the flats on the indirect system are supplied through an oversized down feed pipe, the pipe supplying the hot water apparatus shall be branched from the down feed at a point above the top of the apparatus.
- #4.2.7.1.8 When gas geysers are to be installed on the top floor of a building supplied through storage cisterns, gas geysers with low pressure governors should be installed when the head available is less than 5 metres to the highest hot water draw-off point.
- *4.2.7.1.9 If mixing valves, water blenders or combination fittings are to be used, the cold water supply to these fixtures shall be drawn from the same source as is supplying the hot water apparatus in order to provide a balanced pressure and to obviate the risk of scalding should the supply at the source fail or be restricted for any reason.
- *4.2.7.1.10 Except for unvented electric thermal storage water heaters satisfying the requirements stipulated in Clauses 4.2.7.1.12 and 4.2.7.1.13, all pressure type thermal storage heaters shall be provided with a vent or expansion pipe taken from its highest point and discharge in the atmosphere above the storage cistern at sufficient height to prevent a constant outflow of hot water therefrom.
- *4.2.7.1.11 A loose jumper type valve shall be fitted on the inlet of the water heater if a non-return valve is not incorporated in such water heater, but this requirement does not apply to an electric water heater of the thermal storage type satisfying the requirements stipulated in Clauses 4.2.7.1.12 and 4.2.7.1.13.
- *4.2.7.1.12 All unvented electric thermal storage water heaters shall comply with the safety requirements under the Electrical Products (Safety) Regulation (Chapter 406 sub. leg.).
- *4.2.7.1.13 Every system incorporating an unvented electric water heater of the thermal storage type shall be provided with:-

- (a) a supply pipe that branches off from the feed pipe at a point above the top of the water heater, or some other device to prevent the water from draining down from the water heater if there is a failure at the source of water supply;
- (b) an anti-vacuum valve or some other device to prevent heated water from being syphoned back to the supply pipe; and
- (c) a vessel to accommodate the expansion of heated water where that expansion is constrained by a non-return valve or some other device, incorporated at the inlet of the water heater.

4.2.7.1.14 Not Used.

4.2.7.2 Centralized Hot Water System

#4.2.7.2.1 The cold water feed pipe from the roof storage cistern shall supply to the hot water system only.

#4.2.7.2.2 The cold water feed pipe from sump tank with booster pump shall also be the same source for the hot water system.

#4.2.7.2.3 If mixing valves, water blenders or combination fittings are to be used, the cold water supply to these fixtures shall be drawn by a separate down feed from the hot water storage cistern. This outlet from storage tank shall be slightly lower than the feed to the hot water system in order to provide a balanced pressure and obviate the risk of scalding should the mains supply fail or be restricted.

#4.2.7.2.4 All centralised hot water systems utilising a boiler and cylinder, or calorifier, shall be provided with an expansion pipe taken from the highest point of the cylinder or calorifier, or if a secondary circulation system, from the highest point of such system. In either case the expansion pipe shall discharge to the atmosphere above the storage cistern at sufficient height to prevent a constant outflow of hot water therefrom.

#4.2.7.2.5 Under no circumstances shall safety valves, air valves or relief valves be used as a substitute or replacement for an expansion pipe.

*4.2.7.2.6 Under no circumstances shall any control valve be installed on the expansion pipes between the highest point of the cylinder or calorifier, and the free end of such pipes.

- #4.2.7.2.7 When a centralised hot water system of the boiler /cylinder or calorifier type is installed, in addition to the expansion pipe as required in Clause 4.2.7.2.4, a safety valve or pressure relief valve shall be provided to the boiler or to the primary flow pipe as close to the boiler as possible. Such valve shall be set to discharge when the pressure in the boiler exceeds 35kPa above that of the static pressure of the system.
- *4.2.7.2.8 No tap or other fittings of drawing off water, (other than a screwed plug with a removable key for emptying the system for cleansing and repair), shall be connected to any part of the hot water system below the top of the hot water cylinder in such a way that the level of the water in cylinder can be lowered.
- #4.2.7.2.9 In a hot water system comprising more than one storage cylinders at different levels, Clause 4.2.7.2.8 should read as applying to the lowest cylinder.
- #4.2.7.2.10 To avoid wastage of water when repairs are being effected, a stop valve shall be fitted on the cold feed pipe at the outlet from the storage cistern.
- #4.2.7.2.11 If the storage cylinder is installed in a lower floor, an additional stop valve shall be fitted near the inlet to the cylinder.
- #4.2.7.2.12 Such stop valve as provided under Clauses 4.2.7.2.10 and 4.2.7.2.11 shall have loose keys or hand-wheels which shall be kept in a safe place to prevent unauthorised interference.
- #4.2.7.2.13 A screwed plug with a removable key shall be provided at the lower part of the system for the purpose of draining down or emptying the system.
- #4.2.7.2.14 No stop valve shall be installed in the primary flow or return pipes except when a vent pipe is connected to the boiler and such installation shall only be made under skilled supervision.
- 4.2.7.2.15 Not Used.
- *4.2.7.2.16 Installation of boilers/ steam boilers shall comply with the relevant Boilers and Pressure Vessels Regulations (Chapter 56).
- #4.2.7.2.17 Temperature and pressure relief valve, air vent and vacuum breaker shall be

provided to hot water storage tanks and calorifiers.

4.3 Flushing Water Supply

4.3.1 Sources of Flushing Water Supply

*4.3.1.1 For inside service using government water supply for flushing, it shall comply with the requirements of the WWO/WWR and that of the WA.

#4.3.1.2 For sea-front lots where the private salt water supply is available, mains supply for flushing may be withheld or withdrawn depending on the Lease Conditions.

4.3.2 Pipe & Fitting Materials

#4.3.2.1 All water tanks, pipes and fittings of flushing water systems must be of salt water resistant materials to the approval of the WA. Pipes and fittings shall conform to the relevant standards as listed in Part B of this Technical Requirements and the WWR.

4.3.3 Metering Requirements

#4.3.3.1 All flushing water supply systems shall be separate water supply systems.

4.3.3.2 Not Used.

#4.3.3.3 Water meters shall be installed in each flushing system receiving a TMF supply. TMF flushing water supply would normally be given to the entire building. Requirements stipulated in Section 3 of this TR is applicable.

4.3.4 Supply Modes

#4.3.4.1 Flushing water supply to buildings with an overall height¹⁰ less than or equal to 12m can be effected in one of the two following ways:-

(a) indirect supply system (with direct supply to roof storage tank) as illustrated in Fig. 14; or

(b) indirect supply system, with a sump and pump system or a hydro-pneumatic pump system as illustrated in Fig. 14.

#4.3.4.2 Flushing water supply to buildings with an overall height of more than 12m shall be supplied by indirect supply systems with a sump and pump system as illustrated in Fig. 14 or a hydro-pneumatic pump system or any equivalent system as approved

¹⁰ The meaning of the height of building is similar to that defined under the Buildings Ordinance (Application to the New Territories) Ordinance, Chapter 121. For more detailed illustration, Appendix I to III of the 'Building New Territories Exempted Houses' published by the Lands Department (available in http://www.landstd.gov.hk/en/images/doc/Building_NT_Exempted_Houses_e.pdf) could be referred.

by the WA for all floors. [This clause is applicable to new applications with Form WWO 542 submitted on or after 1 January 2019 except those applications which have Form WWO 132 submitted before 1 September 2018.]

#4.3.4.3 The minimum residual pressure of salt water supply is 15 meter head measured at the connection to the main. The flushing supply inside service should be designed to the minimum residual pressure as advised by the WA.

4.3.5 General Pipework Arrangement

*4.3.5.1 Under the provision of Buildings Ordinance (Chapter 123), all new buildings shall be provided with a plumbing system to supply water for flushing purposes and every part of such plumbing system, including the storage tank, shall be constructed of such materials that are suitable for use with salt water.

*4.3.5.2 A separate water storage tank shall be provided for flushing purposes.

#4.3.5.3 The inlet pipe to the separate storage tank should not be less than 40 mm diameter; its portion before meter position shall be exposed or laid in a proper service duct and extended to the lot boundary.

#4.3.5.4 To facilitate meter installation, a meter position shall be provided in the communal area of the building as close to the fresh supply meters as possible. Regarding general requirements for meter positions, Section 3.2 shall be referred.

#4.3.5.5 In case a temporary mains fresh water supply is proposed to be provided as the alternative source to augment an existing independent (not Government) supply, the storage tank for the flushing cistern shall be constructed in accordance with Fig. 15.

#4.3.5.6 No draw-off point in the inside services shall be subject to a pressure of 6 bar or above.

#4.3.5.7 To facilitate future maintenance and testing for flushing pipe leakage, a tee branch valve for each individual premises shall be provided for all flushing pipes at locations where the valve could be reached from the premises and as close to the common pipe as practicable.

#4.3.5.8 Concerning requirement for flushing water storage capacity, Clause 6.2.5 shall be

referred.

#4.3.5.9 All PVC-U pipes must be properly supported and shielded from direct sunray and must be painted with protective paint when exposed. The paint should not adversely affect the physical property of the PVC-U pipes.

4.4 Not Used.

4.5 Not Used.

5. Fire Service

5.1 General

- 5.1.1 Not Used.
- 5.1.2 Not Used.
- #5.1.3 Plumbing systems using government water supply for fire services shall comply with the requirements of the WA.
- *5.1.4 The use of water from fire service for purposes other than firefighting is prohibited.

5.2 Metering Requirement

- #5.2.1 Details of master meter and check meter positions shall be referred to Section 3.3.

5.3 Pipe & Fitting Materials

- #5.3.1 Pipe and fittings shall conform to the relevant standards as listed in Part B of this Technical Requirements and the WWR.
- #5.3.2 Consideration can be given for the use of wrought iron pipe and black steel pipe without being galvanized, upon application, for a fresh water fire service after a positive air break, i.e. fire service tank or sump tank.
- #5.3.3 The materials for pipes and pipe fittings on a salt water fire service shall be capable of withstanding the corrosive effect of salt water.

5.4 Supply Types and Arrangements

5.4.1 General

- #5.4.1.1 Fire service supply may be from fresh water or salt water source. The supply must be from an independent connection, i.e. entirely independent of other water supply arrangements within the building or development concerned.

#5.4.1.2 For existing buildings, fire service installations obtaining water supply from existing fresh water tanks may be considered case-by-case by the WA and the Director of Fire Services.

5.4.1.3 Not Used.

#5.4.1.4 All plumbing works between the lot boundary and master/check meter positions shall be exposed or laid in a proper service trench/duct to facilitate inspection and repairs. Adequate drainage shall be provided to remove water inside the trench/duct.

#5.4.1.5 If the connection is not laid in an exposed manner at the lot boundary, then it shall be laid inside underground service trench/duct with adequate cover. The underground/buried water mains should be laid with cover according to the latest required minimum depth of services and associated installations stipulated by Highways Department. The current minimum cover requirements stated in the Conditions of Excavation Permit are 450mm and 900mm on non-carriageway and carriageway respectively.

#5.4.1.6 A fullway gate valve and a non-return valve have to be installed on the fire service as close to the Government water supply connection as possible.

5.4.2 Sprinkler/ Drencher System

5.4.2.1 Not Used.

#5.4.2.2 A dual connection from the Government unrestricted supply ring main shall be provided for a fire service sprinkler / drencher system situated in the recognised Waterworks unrestricted industrial supply zone. Twin connections, one from an unrestricted supply main and one from a distribution main, will be provided for a fire service sprinkler / drencher system situated outside the recognised unrestricted industrial supply zone, where practicable.

#5.4.2.3 Where it is not practical to connect the fire service sprinkler / drencher system to an unrestricted supply main, FSD may require the provision of fire service tank to serve as secondary source for the fire service installation. Depending on FSD's requirements, a single or dual connection can be given to serve the fire service tank of secondary source.

#5.4.2.4 No part of any fire service sprinkler / drencher system supplied from the

Government mains shall be used for supplying any other services including other fire service installations, e.g. hose reels, except that a common suction tank can be used for both sprinkler and hose reel systems. Any exemption from this requirement should have the endorsement of the Director of Fire Services.

#5.4.2.5 Where direct connections to a sprinkler/ drencher system are to be from the government mains, an additional butterfly valve, without stop screw and lock nut on handle and strapped in open position, shall be installed at a point on the supply pipe before the fire service inlet and as close as possible to the control valves of the connections.

#5.4.2.6 FSD's endorsement shall be sought for the application for improvised sprinkler systems as illustrated in Fig. 17. The design of the improvised system shall be vetted by Fire Services Department.

5.4.3 Fire Hydrant/ Hose Reel System

#5.4.3.1 The water supply must not be fed directly from the government mains and the fire hose reel outlet should be housed in a glass-fronted cabinet secured under lock and key. The glass panel shall be of a frangible type and shall not exceed 1.5 mm in thickness, and that it shall be of such size and design so as not to cause any undue obstruction to the free use of the hose reel. A metal or plastic striker shall be provided in the vicinity of the cabinet for the purpose of breaking the glass panel in case of emergency.

#5.4.3.2 Common tank arrangements for fire-fighting and flushing or other purposes are not acceptable when a government supply is involved. Where a building is to be provided with a non-government flushing supply and where it is proposed to feed the fire service from that supply, the applicant is advised to install an independent fire service system if it is envisaged that the fire service system may require to be connected to the government main at a later stage.

- #5.4.3.3 Warning message shall be securely fixed on or near every hose reel outlet and the message shall be easily visible by the occupier.

消防用水
嚴禁作其他用途

USE OF WATER FROM FIRE SERVICES
FOR PURPOSES OTHER THAN FIRE
FIGHTING IS STRICTLY PROHIBITED

水務監督辦事處 Office of the Water Authority

5.4.4 Street Fire Hydrant System

- 5.4.4.1 Not Used.

- #5.4.4.2 Typical layout drawing for street fire hydrant system in Fig. 21 should be followed.

5.4.5 Fire Service Ring Mains

- #5.4.5.1 Where in large industrial complexes a fire service ring main is required, this should be connected to an unrestricted supply main, if practical. In cases where this is not practical, a 'dual' connection from the government ring main should be provided.

- #5.4.5.2 Fire service ring mains shall not be connected to or used for supplying any other service, except with the approval of the WA.

5.4.6 Not Used.

5.4.7 Not Used.

5.4.8 Not Used.

5.4.9 Not Used.

6. Water Cisterns, Water Pumps and Other Miscellaneous

6.1 General

- *6.1.1 No cistern for the storage of cold water shall be installed or used except with the permission in writing of the WA who shall specify the maximum permitted capacity.
- *6.1.2 No cistern for the storage of fresh water supplied from the waterworks shall, without the written permission of the WA, be so connected that it can be used for the storage of any water other than that supplied from the waterworks.

6.2 Cold Water Cisterns (or Cold Water Tanks)

6.2.1 Location

6.2.1.1 Access for Maintenance and Inspection

- *6.2.1.1.1 Water Storage Tanks shall be installed so that they are easily accessible for cleaning or repairs.
- *6.2.1.1.2 Safe access shall be provided to all cisterns by means of a secure permanent ladder or readily available portable ladder.
- *6.2.1.1.3 Where a cistern is installed inside a building and, due to limited headroom available, it is fixed with limited clearance from the ceiling or underside of the roof, a quickly detachable fitting must be used to enable it to be easily removed for cleansing and repair.
- #6.2.1.1.4 For water cisterns with top access, the access on top of the cisterns should have a minimum headroom of 800mm.
- #6.2.1.1.5 Safe, free and uninterrupted access to the water cisterns should be provided and maintained at all time to ensure the safety of personnel undertaking cleaning or maintenance works.

6.2.1.2 Protection against Pollution of Potable Water by Non-Potable Water

- *6.2.1.2.1 If a cistern for non-potable water is placed adjoining to a cistern for potable water, a physical break must be provided between the cisterns, such that the walls and slabs of the cisterns are separated, however, tie beams linking the cisterns for structural requirements may be fitted and, if fitted, must be constructed in a way that cross contamination of the cisterns via the tie beams is not possible.

#6.2.1.2.2 A non-potable water cistern shall not be placed above a potable water cistern in the same compartment of the building. If a cistern for non-potable water is placed above a cistern for potable water due to site constraints, a physical break must be provided between the cisterns, such that the walls and slabs of the cisterns are separated. Full justifications and details for such arrangement shall be provided to the WA for consideration and approval.

6.2.2 Material Requirements

*6.2.2.1 A cistern must be watertight, of adequate strength, properly supported and be made of concrete, stainless steel or fibre glass.

#6.2.2.2 For concrete fresh water cisterns/storage tank, all internal surface of floors, walls (to full height) and soffits of potable water cisterns shall be lined with a non-toxic smooth finish.

6.2.2.3 Not Used.

#6.2.2.4 When fibreglass storage tank is to be used, prior approval by the WA must be sought. Fibreglass storage cistern for potable water shall be of an approved type or certified to contain no toxic materials and suitable for storage of potable water.

6.2.2.5 Material testing standards and requirements of fresh water tanks in inside service is given in Part B of this TR.

#6.2.2.6 All sealing compound, cover or other materials, no matter in contact or not in contact with potable water, adopted for sealing any opening at the internal surface of potable water cisterns shall be non-toxic.

6.2.3 Cover for Water Tanks

*6.2.3.1 A cistern must be so located as to minimize the risk of contamination of stored water and be fitted with a suitable close fittings lockable cover that is not airtight. The cover must be so positioned as to facilitate inspection and cleaning.

#6.2.3.2 Every storage cistern shall have a lockable close fitting rigid cover secured by mechanical means which excludes light and the ingress of particles and / or insects from the cistern. The cover shall be made of a material or materials which do not shatter or fragment when broken and which will not contaminate any condensate which may form on its underside or the stored water. For the potable water storage

cistern, the cover and its base frame shall possess double upstand edges interlocking one another to provide additional protection.

#6.2.3.3 Double sealed covers with locking devices shall be provided for all storage cisterns other than cisterns that provide supply solely for irrigation, cleansing, air-conditioning system make-up water, flushing and fire-fighting. The double-sealed covers prevent the ingress of surface water.

6.2.4 Installation Requirements for Inlet and Outlet Pipes

6.2.4.1 Minimization of Water Stagnation

#6.2.4.1.1 All outlet pipes from the storage cistern should, whenever possible, be positioned at the opposite side to the inlet supply pipe to prevent stagnation of water.

6.2.4.2 Controlling Incoming Water Supply

*6.2.4.2.1 The inlet of a single cistern fed by a gravity supply must be fitted with a ball float valve and stop valve.

*6.2.4.2.2 For ball float valves of a nominal diameter not exceeding 50mm, their valve bodies must be made of copper alloy or stainless steel. For ball float valves of a nominal diameter exceeding 50mm, their valve bodies must be made of copper alloy, stainless steel, epoxy coated cast iron or epoxy coated ductile iron.

*6.2.4.2.3 Floats for use with fresh water must be made of copper alloy or stainless steel. Floats for use with salt water must be made of plastic or stainless steel.

*6.2.4.2.4 Ball float valves fitted to a cistern must have the size of the orifice, the size of the float and the length of the lever so proportioned to one another that, when the float is immersed to an extent not exceeding half its volume, the valve is watertight against the highest pressure at which the valve may be required to work.

*6.2.4.2.5 A ball float valve or float-operated valve fitted to a cistern must be securely fixed to the cistern above the waterline of the float of the valve, and must be supported independently of the inlet pipe (unless the inlet pipe is itself rigid and securely fixed to the cistern), in a position that no part of the body of the valve is submerged when the cistern is charged to the overflowing level.

*6.2.4.2.6 If a ball float valve or float-operated valve is provided with a pipe so arranged as to discharge water into a cistern below its overflowing level, an air hole must be

provided in the outlet chamber of the valve above the overflowing level. The air hole must be of a size sufficient to prevent syphonage of water back through the valve.

- *6.2.4.2.7 Ball float valves must not be fitted to a cistern that is used to contain heated water.
- *6.2.4.2.8 The inlet of a single cistern fed by a pumped supply must be fitted with an automatic control switch and without any stop valve.
- *6.2.4.2.9 A ball float valve or automatic control switch installed at the inlet of a cistern must shut off the supply when the water level is 25mm below the invert of the overflow pipe or warning pipe. The invert of the inlet pipe or the outlet of the ball float valve must not be less than 25mm above the top of the overflow pipe.
- #6.2.4.2.10 In case of a mixed flushing water supplies, the water tank shall be fitted with a ball float valve with submerged float control and a fullway gate valve for controlling and isolating the inflow of mains supply respectively. For other source of flushing water supply, a ball float valve and a fullway gate valve shall be provided. Typical detail for flushing water tank with mixed supply is illustrated in Fig. 15. Performance of the ball float valve shall meet the requirements specified in case of gravity supply.

6.2.4.3 Outlet Water Pipes

- #6.2.4.3.1 The invert of an outlet pipe from a water storage cistern with capacity less than 5,000 litres shall be at least 30 mm above the bottom of the cistern; this distance shall be increased to 100 mm if the capacity is 5,000 litres or more.
- *6.2.4.3.2 A stop valve must be provided at the outlet of a cistern. Provisions must be made for a drain-off pipe to enable the cistern to be emptied.
- #6.2.4.3.3 Fullway gate valves shall be used with as the stop valves in Clause 6.2.4.3.2 at the outlet pipe of every water storage cistern. The drain-off pipe in Clause 6.2.4.3.2 shall be properly plugged or adequate means shall be provided to prevent any unauthorized operation of the control valve at drain-off pipe. If the outlet of a flushing water cistern is of nominal size 50mm or below, a ball valve can be used to substitute the above gate valve.

6.2.4.4 Overflow Pipes and Warning Pipes

- *6.2.4.4.1 All overflow pipes and warning pipes of a potable water cistern must be made of a

corrosion-resisting material.

- *6.2.4.4.2 An overflow pipe of one commercial size larger than the inlet pipe, and in no case less than 25mm in nominal diameter, must be fitted to a cistern and be extended to terminate in a conspicuous position. The overflow pipe must not be connected to a drain or sewer or to the overflow pipe from another cistern.
- #6.2.4.4.3 The position of discharge should be in a communal area easily visible and accessible by the occupants.
- #6.2.4.4.4 If the overflow pipe is not extended to terminate in a conspicuous position, the overflow pipe shall be installed with an overflow alarm with signal transferred to a 24-hourly manned management office for timely notification. Full justifications for such arrangement shall be provided to the WA for consideration and approval.
- #6.2.4.4.5 In case of mixed flushing water supply as shown in Fig. 15, the overflow shall be twice the diameter of largest inlet or of nominal diameter 40mm, whichever is greater.
- #6.2.4.4.6 No part of the overflow pipe shall be submerged inside the storage tank.
- #6.2.4.4.7 A grating and a self-closing non-return flap shall be provided at the overflow pipe outside the storage tank.
- #6.2.4.4.8 A warning pipe shall be installed in addition to an overflow pipe. A warning pipe can be of any size not less than 25 mm in diameter and shall comply with all other requirements of an overflow pipe.
- #6.2.4.4.9 The warning pipes shall be installed at a level below the overflow pipe and shall be either extended to conspicuous location, i.e. outside of the building periphery for roof tank or outside the pump room for sump tank, or installed with signal transferred to a 24-hourly manned management office.
- #6.2.4.4.10 Any openings of storage cistern shall be properly covered with non-corrodible or corrosion-resistant mesh (with size of opening not more than 2 mm) to prevent the ingress of any small animal, insect or foreign matter into the water tank.

6.2.5 Size of Storage Cisterns for Flushing, Domestic and Trade/Commercial Water Uses

- #6.2.5.1 The proportion of capacity of sump cistern to roof cistern is recommended to be in

the order of 1:3. Otherwise, the designer shall demonstrate that the proposed ratio of sump cistern to roof cistern is capable of fulfilling the designed demand.

- #6.2.5.2 The capacity of the flushing water storage shall be designed according to the criteria in Table 6.2.5.2.1 with a minimum capacity of 250 litres. [This clause is applicable to new applications with Form WWO 542 submitted on or after 1 January 2019 only.]

Table 6.2.5.2.1 Design criteria for flushing water storage

Building types	Litres per flushing apparatus
1. Residential - Water closet	30
2. Commercial - Urinal	30
- Water closet	40

- #6.2.5.3 Storage criteria for fresh water supply for domestic flats are given in Table 6.2.5.3.1.

Table 6.2.5.3.1 Storage criteria for domestic application (sump and pump system)

Up to 10 flats	135 litres/flat In case of a sump and pump system, the minimum total storage including sump tank is allowed to be 500 litre,
> 10 flats	90 litres for each additional flat

- #6.2.5.4 For industrial buildings, the entire inside service shall be supplied from storage cisterns with separated outlets/downpipes feeding independent systems to serve separately the industrial and processing purposes and the other general and ablution appliances. These independent systems shall not be interconnected.

- #6.2.5.5 The required capacity of storage tanks for industrial use is one-day demand.

- #6.2.5.6 For trade/commercial premises, the storage criteria for fresh water supply shall be designed according to the criteria in Table 6.2.5.6.1 and Sections 6.2.5.7 to 6.2.5.9. The criteria shall apply to building types not listed below, yet having similar functions. In addition, designers should avoid oversize or undersize of the storage of water tanks which may result in water quality problems. However, applicant may request for relaxation of the requirement with justifications and flexibility will be allowed by the WA if justified.

Table 6.2.5.6.1 Storage criteria for trade/commercial fresh water supply

Food Shop	(Small)	900 litres	Not including provision of stores, fruiterers, etc.
	(Large)	1800 litres	
Restaurants		25 litres/seat (0.929m ² /person on net area) (1.394m ² /person on gross area)	
Barber's Shop and Beauty Parlour		135 litres/chair	
Funeral Parlour		45 litres/92.903m ² on gross area	
School	Drinking	4.5 litres/head	
	Laboratory	45 litres/sink	
Industry		100% of daily demand	
Clinic		250 litres (surgery only)	
Dentist		250 litres/dental unit	
Clubs	Kitchen	2.5 litres/member	
	Changing Rooms	90 litres/shower (hot and cold combined)	
Office Blocks		45 litres/point	
Cinemas/Theatres		45 litres/point	
Hotels	Bedrooms	45 litres/single room (hot and cold combined) 70 litres/double room (hot and cold combined)	
	Pantries, Bars and Laundries	Individual consideration	
Boarding Houses and Staff Quarters		25 litres/bed (hot and cold combined)	
Fire Stations, Police Quarters, Army Barracks		45 litres/person x 50% of establishment (ablution rooms only – hot and cold combined)	

#6.2.5.7 For laundry, the required storage criterion is given in Table 6.2.5.7.1.

Table 6.2.5.7.1 Storage criterion for laundry

<p>Laundry Allowable Storage = $\frac{L}{T} \times 120 \text{ min.} \times N$</p> <p>where L = Litres/complete operational cycle T = Time/complete operational cycle N = No. of machines</p>

#6.2.5.8 For hospital, the required storage criterion is one day's consumption as given by the hospital authorities.

#6.2.5.9 For boilers, the required storage criterion is given in the following formula:-

$$\text{Allowable Storage (litres)} = (\text{Boiler capacity (kW)} \times 15 - \text{percentage of water return (\%)}) \times \text{working hours.}$$

6.2.6 Other Requirements

6.2.6.1 Not Used.

#6.2.6.2 When the capacity of water cistern exceeds 5,000 litres, adoption of twin-tank system is required. The applicability shall also be subject to factors such as availability of plant room space.

#6.2.6.3 A set of inlet, outlet and associated overflow and drain pipes shall be provided to each cistern compartment.

*6.2.6.4 Each inlet of a twin-cistern fed by a pumped supply must be fitted with an automatic control switch and a stop valve for temporary isolation purpose.

#6.2.6.5 For water supplies other than pumped supply, this inlet shall comply with requirements stated in Clause 6.2.4.2.1.

6.3 Water Pumps

#6.3.1 Where a sump-and-pump system is used, it shall be provided with a duplicate pumpset. The pumping capacity of the pumps shall not be less than the designed out-flow rate of the storage tank being supplied.

6.3.2 Not Used.

6.4 Not Used.

6.5 Pressure Reducing Valves

#6.5.1 No part in the internal pipework and/or draw-off point shall be subject to excessive high pressure. In case of excessive high pressure, provision of break pressure tanks at a suitable level of the internal supply system would be a positive and viable means to reduce the water pressure. Alternatively, pressure reducing valves may be provided in lieu of break pressure tank.

#6.5.2 Whenever a pressure reducing valve is installed, a bypass arrangement shall be incorporated with the provision of a second pressure reducing valve, except for fire service installations, to enable isolation of any defective pressure reducing valve for repair and replacement when necessary. A pressure indicator shall be provided for pressure monitoring and the associated pipes and fittings shall be able to withstand the maximum pressure that may arise upon the failure of the pressure reducing valve as far as practicable. Fault alarm shall be installed with signal transferred to a 24-hourly manned management office for timely notification, except for fire service installations.

6.6 Stop Valves for Draw-off Points

#6.6.1 Individual stop valves shall be provided at all draw-off points or at a series of draw-off points if situated close together.

6.6.2 Not Used

6.7 Water Taps

6.7.1 Application of Water Taps

#6.7.1.1 When infra-red sensor operated automatic taps are used as inside services, a stop cock or gate valve must be installed at the upstream of each fitting for manual isolation of water supply.

#6.7.1.2 Self-closing taps, of non-concussive type and of approved pattern, or infra-red operated automatic taps, shall be used for the public or communal lavatory basins.

*6.7.1.3 Except with the written permission of the WA, fitting with a threaded outlet, or any device facilitating the connecting of rubber hose or another type of flexible hose, must not be used.

6.7.2 Installation Requirements for Sanitary Fixtures Supplied by Water Taps

*6.7.2.1 All taps supplying baths, lavatory basins, sinks or similar apparatus shall have a stop valve fixed in a readily accessible position to control the supply to each fitting or branch pipe supplying a range of fittings.

*6.7.2.2 Every inlet to a bath, lavatory basin or sink shall be distinct from, and unconnected with, any outlet therefrom and every outlet for emptying such bath, lavatory basin

or sink shall be provided with a well-fitting and easily accessible watertight plug or some other equally suitable apparatus.

- *6.7.2.3 The level of the point of discharge of hot or cold water to a bath, lavatory basin or sink shall be above the level of the overflow, or if there be no overflow, of the top edge of the bath, basin or sink.
- *6.7.2.4 The water supply to any bidets, sitz bath, slop or sluicing sink or similar apparatus, shall, if the inlet is liable to be submerged, be provided by:-
 - (a) a cistern supplying water to such apparatus only;
 - (b) a cistern for flushing purposes only; or
 - (c) a hot water distribution system supplying such apparatus only.

6.8 Domestic Appliances

6.8.1 Water Purifiers/ Filters

6.8.1.1 Not Used.

#6.8.1.2 Domestic water purifiers/ filters must not be connected directly to the mains supply because of the possibility of contamination.

#6.8.1.3 When there is installation of any domestic filter or water filter incorporated in water using apparatuses (such as drinking fountain etc.), backflow prevention device shall be installed.

#6.8.1.4 Requirements for backflow prevention and written permission from the WA for typical types of water filters are summarized in Table 6.8.1.4.1.

Table 6.8.1.4.1 Installation requirements for water filters

Type of water filters	Availability of an Off-tank Water Supply	Written Permission from the WA	Installation of Backflow Prevention Device
Faucet filters or Countertop filters	Yes	Not required; The customer can install himself.	Not required
	No.	Not required; The customer has to engage a licensed plumber to install.	Required A non-return valve either within the filter or upstream of the filter without any branch pipe in between the valve and the filter
In-line filter of Point-of-Use (POU) type ¹	Yes or No.	Required; Plumbing proposal is required.	Required A single check valve or no less effective backflow prevention device is provided upstream of the filter and there is no branch pipe in between the device and the filter
In-line filter of Point-of-entry (POE) type ²	Yes or No.	Required; Plumbing proposal is required.	Yes. Water supply from storage tank is mandatory.

¹ Point-of-Use (POU) type in-line filter may serve a single water point e.g. drinking fountain etc. under direct or indirect water supply.

² Point-of-Entry (POE) type in-line filter may treat water from the mains serving a premise.

#6.8.1.5 Sterilizers with or without attached filtering devices could be connected directly to the mains supply provided that backflow prevention device is provided upstream of the sterilizer such that there is no possibility of contaminating the mains supply.

6.8.2 Washing Machines and Dishwashers

6.8.2.1 Not Used.

#6.8.2.2 Regarding non-domestic use of washing machines and dishwashers, appropriate backflow prevention devices must be installed according to Table 4.2.3.7.2.

6.8.2.3 Not used.

#6.8.2.4 Domestic use washing machines and dishwashers shall comply with Electrical Products (Safety) Regulation (Cap. 406G) and no extra backflow prevention measures is required; otherwise a double check valve must be installed.

6.8.2.5 Not used.

6.9 Not Used.

6.10 Flushing Apparatus

6.10.1 General Requirements

6.10.1.1 Not Used.

*6.10.1.2 A flushing cistern must in all cases be supplied from a cistern. Except with the written permission of the WA, the cistern must not be used to supply any other apparatus, appliance or fitting. The cistern must be fitted with a suitable close fitting cover and provided with appropriate access to enable the cistern to be entered and cleaned.

*6.10.1.3 A trough water-closet or urinal must be fitted with a flushing cistern.

*6.10.1.4 A water-closet fitment or slop sink must be fitted with a flushing cistern. However, a pressure flushing valve may be installed for flushing without the provision of a flushing cistern if there is a suitable head of water.

*6.10.1.5 The internal diameter of flushing pipes shall:-

- (a) in the case of water-closet fitments, trough water closets and slop sinks, be not less than 30mm;
- (b) in the case of urinals (other than trough urinals), be not less than 15mm for each basin and stall; and
- (c) in the case of trough urinals, be not less than 15mm for every metre thereof.

*6.10.1.6 A flushing apparatus must be operated by mechanical means or a sensor. In the case of an automatic flushing apparatus, the method of control and the volume and frequency of the flushes must be designed to ensure adequate cleaning.

6.10.2 Flushing Cisterns

*6.10.2.1 A flushing cistern must be fitted with a flushing device of the valveless syphonic or valve type. A stop valve must be fixed in a readily accessible position so as to control the water supply to the cistern.

- *6.10.2.2 A flushing cistern for a water-closet fitment or slop sink must be capable of giving a flush of not more than 15 litres of water on each occasion the fitment is used.
- *6.10.2.3 The capacity of the flushing cistern in the case of trough water closets and urinals shall be approved by the WA subject to the discharge in the case of trough water closets being not less than 9 litres of water for every metre of the channel and the discharge in the case of urinal being not less than 4.5 litres of water for every basin or stall, or in the case of a trough urinal, every metre thereof.
- #6.10.2.4 The WA would have no objection to accepting the use of flushing cisterns with discharge less than that required by the current regulations provided that the design flushing volume is compatible with the toilet bowl to ensure effective clearance of waste by a single flush and the flushing apparatus meets the requirements of the WA.
- *6.10.2.5 A flushing cistern operated by mechanical means or a sensor must be fitted with a ball float valve that is arranged to refill the cistern within 2 minutes.
- *6.10.2.6 Every flushing cistern shall have an overflow which shall discharge in a conspicuous location.
- 6.10.2.7 Not Used.
- #6.10.2.8 The requirements on the use of valve type flushing cisterns are as follows:-
 - (a) The valve seal of the flushing devices shall be easily replaceable;
 - (b) A dual flush valve which is designed to give two different volumes of flush shall have a readily discernible method of actuating the flush at different volumes. Such method should be illustrated clearly and permanently displayed at the cistern or nearby;
 - (c) For dual flush devices, the reduced flushing volume shall not be more than two-thirds of the larger flushing volume; and
 - (d) The flushing devices must pass the 200,000-cycle endurance test.
- *6.10.2.9 The components of all valve type flushing devices shall be of material that is suitable for the use of salt water.
- *6.10.2.10 For an existing building with permission to use government water supply for

flushing purposes, any existing flushing apparatus found unsuitable shall be replaced with a proper apparatus as specified under Section 6.10.

#6.10.2.11 A filter which is readily accessible for inspection and cleaning shall be installed before a flushing valve. This filter can be replaced by a built-in strainer, which can be readily inspected and cleaned, in the flushing device.

6.10.3 Flushing Valves (Flushometers)

#6.10.3.1 The installation of flushing valves (flushometers) shall be permitted when the following requirements are fulfilled:-

- (a) A filter/strainer shall be installed before a flushing valve or a group of flushing valves;
- (b) The cartridge and other valve components shall be easily replaceable;
- (c) Flushing valves shall be used within the range of working pressures specified by the manufacturer;
- (d) The flushing valves must pass the 200,000-cycle endurance test;
- (e) An effective maintenance management system shall be provided for frequent inspection and cleaning of filters, i.e. normally only public toilets (administered by government, quasi-government bodies, hotel operators, commercial complex management offices etc.) will be considered;
- (f) A plate etched with the name of the responsible party and the telephone number in both Chinese and English shall be provided to facilitate users to report defective flushing valves. Other effective arrangements may also be considered; and
- (g) Flushing valves shall be of water efficiency Grade 1 or Grade 2 under Water Efficiency Labelling Scheme (WELS). Sections 7.3 shall be referred for details.

*6.10.3.2 The valve components shall be of material that is suitable for the use of salt water.

*6.10.3.3 For an existing building with permission to use mains water (fresh or salt) for flushing purposes, any existing flushing apparatus found unsuitable shall be replaced with a proper apparatus as specified under Section 6.10.

6.11 Earthing

#6.11.1 The metal work of an inside service shall not be used as an earth electrode. The use of non-metallic pipes or fittings should not have had any effect on the earthing arrangement of the building.

6.11.2 Not Used.

7. Water Conservation

7.1 General

#7.1.1 To uplift the standard of water efficiency of plumbing fixtures and appliances, a mandatory Water Efficiency Labelling Scheme (WELS) has been implemented. For all proposed plumbing works submitted using the Form WWO 46 for designated part of premises as listed below, the proposed products to be used for shower heads for bathing, water taps, urinal flushing valves and water-closet fitments¹¹ should comply with prescribed water efficiency grades registered under WELS.

7.2 Minimum Flow Requirements for Fittings and water-closet fitments in Inside Service

#7.2.1 The minimum flow requirements for draw-off taps, single and combination taps shall conform to the specification in the relevant international standards. Relevant standards for respective tapware has been summarized in Part B of this TR.

7.3 Water Efficiency Requirements for Fittings and water-closet fitments in Inside Service

#7.3.1 Subject to exemption stipulated in Section 7.5.1, designated products (showers for bathing, water taps and urinal flushing valves) of prescribed water efficiency requirements registered under WELS shall be used in the following designated part of premises:-

- i. Kitchens of the domestic premises; and
- ii. Bathrooms and toilets of all premises.

#7.3.2 the products shall comply with the prescribed water efficiency requirements in Table 7.3.2.1 below:-

Table 7.3.2.1 Prescribed water efficiency requirements for designated products

Designated products	Prescribed water efficiency requirements
Showers for bathing ¹	Grade 1 or Grade 2
Water taps (for use in kitchen sinks) ²	Grade 1 or Grade 2 or Grade 3
Water taps (for use in washing basins of bathrooms and toilets) ²	Grade 1 or Grade 2
Urinal flushing valves	Grade 1 or Grade 2

¹¹ In accordance with Section 4.6 of the Scheme Document for WELS on water closets, the term “water closet” covers toilet suite (one-piece water closet pan); water closet pan only; water closet cistern only; and a combination of a water closet pan and cistern (close-coupled suite).

¹ 'Showers for bathing' cover showerheads installed to fixed arms/concealed pipes in the wall or ceiling, showerheads installed to pivotal arms and hand-held showers.

² 'Water taps' cover mixing or non-mixing type water taps installed at bathroom/toilet washing basins and pantry/kitchen sinks. Water taps equipped with automatic sensing open/close device or automatic closing mechanism are also included. However, water taps installed at bath tub/shower, any system, machinery and devices such as irrigation system, washing machines, water dispensers etc. which serve for bathing/operational use, are excluded. Water taps for construction purposes are exempted.

7.3.3 Not Used.

#7.3.4 Subject to exemption stipulated in Section 7.5.2, all water-closet fitments proposed in Form WWO 1149 (the "List of Pipes and Fittings") for proposed plumbing works should comply with the prescribed water efficiency requirements as detailed in the Table 7.3.4.1 below.

Table 7.3.4.1 Prescribed Water Efficiency Requirement of Water-closet Fitment for Designated Parts of Premises

Designated parts of premises	Prescribed water efficiency
(a) Toilet(s) of domestic premises	Grade 1 or Grade 2
(b) Toilet(s) of non-domestic premises, without automatic sensing flushing apparatus(es)	Grade 1 or Grade 2
(c) Toilet(s) of non-domestic premises, with automatic sensing flushing apparatus(es)	Grade 1, Grade 2 or Grade 3
(d) Disabled toilet(s) of any premises	Grade 1, Grade 2 or Grade 3

7.4 Alternatives to Application of WELS Products

#7.4.1 For water taps or showers for bathing not complying with the above water efficiency requirements in Table 7.3.2.1, the WA will accept the alternative of installing a flow controller inside the water tap or shower for bathing. The flow controller shall be a registered product under WELS and shall be of appropriate water efficiency grade to form a 'combined' water saving device that meets the prescribed water efficiency requirements.

#7.4.2 When submitting the Form WWO 46, test report(s) of flow rate test on the 'combined' water-saving appliance(s) shall be enclosed to demonstrate compliance with the prescriptions in Table 7.3.2.1. The test shall be conducted within 5 years before the date of submission.

7.5 Exemption from the Water Efficiency Requirements

#7.5.1 Applicants may apply for exemption from the requirements within the scope of designated part of premises under the scenarios described in Clauses 7.5.1a to 7.5.1c.

#7.5.1a Scenario A

All premises with tenders/quotations concerning the installation of showers for bathing, water taps or urinal flushing valves therein invited before 1 February 2017 may be eligible for exemption from the mandatory use of designated products registered under WELS. To apply for exemption, in the submission of the Form WWO 46, the applicant shall: (a) submit documentary proof of such tender/quotation or the existence of such tender/quotation; and (b) demonstrate that the specifications stipulated under the said tender/quotation for the use of those designated products could not fulfil the prescribed water efficiency requirements to the WA for verification and approval.

#7.5.1b Scenario B

For all premises, applications for exemption based on technical issues like inadequate water pressure for the operation of water heater after the installation of designated products will also be considered on a case-by-case basis. To apply for exemption, the applicant shall provide information to fully justify why the mandatory use of designated WELS products cannot be complied with in the submission of the Form WWO 46.

#7.5.1c Scenario C

For all premises, applications for relaxation of requirements based on reasons other than those under scenarios (A) or (B) will also be considered on a case-by-case basis. The relaxation may be in the form of relaxing the flow rate requirements of certain designated products or exempting certain designated part of premises from the mandatory requirements. To apply for the relaxation, the applicant shall provide detailed information in the submission of the Form WWO 46 to fully justify why the mandatory use of designated WELS products cannot be fully complied with.

#7.5.2 For Form WWO 1149 submitted after 1 December 2020, an applicant may apply for exemption from the requirements within the scope of designated part of premises under the scenarios described in Clauses 7.5.2a to 7.5.2c.

#7.5.2a Scenario (A)

All premises with tenders/quotations concerning the installation of water-closet fitments therein invited before 1 December 2019 may be eligible for exemption from the mandatory use of water-closet fitments complying with the prescribed water efficiency grades registered under WELS.

To apply for exemption, in the submission of Form WWO 1149, the applicant shall:

- (a) submit documentary proof of such tender/quotation or the existence of such tender/quotation; and
- (b) demonstrate that the specifications stipulated under the said tender/quotation for the use of those water closets could not fulfill the prescribed water efficiency requirements to the WA for verification and approval.

#7.5.2b Scenario (B)

For all premises, applications for exemption based on technical issues will also be considered on a case-by-case basis. To apply for exemption, the applicant shall provide information to fully justify why the mandatory use of water-closet fitments complying with the prescribed water efficiency grades registered under WELS cannot be complied with in the submission of Form WWO 1149.

#7.5.2c Scenario (C)

For all premises, applications for relaxation of requirements based on reasons other than those under scenarios (A) and (B) will also be considered on a case-by-case basis. The relaxation may be in the form of relaxing the flush volume requirements of water-closet fitments or exempting certain designated part of premises from the mandatory requirements. To apply for the relaxation, the applicant shall provide detailed information in the submission of Form WWO 1149 to fully justify why the mandatory use of water-closet fitments complying with the prescribed water efficiency grades registered under WELS cannot be fully complied with.

7.6 Not Used.

Part B: Plumbing Material Standards and Requirements

B1. Introduction

B1.1 This document standardizes the applicable standards and test requirements for plumbing material components including:-

- Pipes and fittings;
- Valves;
- Taps and mixers;
- Products covered by Water Efficiency Labelling Scheme (WELS); and
- Other materials

B2. Pipes and Fittings to be Used in Inside Service or Fire Service

B2.1. Products subject to Approval by the WA

B2.1.1 Pipes or fittings for use in Inside Service or Fire Service shall comply with a prescribed specification in accordance with the Waterworks Regulations.

In general, suitable pipe materials for inside service and fire service are as follows:-

- (a) Pipes for a fresh water inside service must be made of ductile iron, unplasticized polyvinyl chloride (PVC-U), steel, stainless steel, copper, polyethylene (PE), crosslinked polyethylene (PE-X) or chlorinated polyvinyl chloride (PVC-C). However, pipes made of polyethylene or unplasticized polyvinyl chloride must not be used for hot fresh water inside service. Pipes and fittings made of polybutylene (PB) are not permitted to be used in fresh water inside service ;
- (b) Pipes for a salt water inside service must be made of ductile iron, polyethylene or unplasticized polyvinyl chloride;
- (c) Pipes for a fresh water fire service must be made of ductile iron, steel, stainless steel or copper; and
- (d) Pipes for a salt water fire service must be made of steel and internally lined with chlorinated polyvinyl chloride or of ductile iron.

B2.1.2 WSD has a General Acceptance (GA) system in place to pre-approve plumbing products used in plumbing projects. To obtain approval for the installation and use of pipes or fittings in inside service or fire service covered by the Waterworks Ordinance/Waterworks Regulations from this Authority, the GA applicant is required to produce one set of certification or test reports confirming their compliance with the relevant prescribed specification as listed on WSD webpage from either (a) the British Standards Institution, (b) the U.K. Water Regulations Advisory Scheme or (c) accredited laboratories acceptable to this Authority. For (a)

and (b), please ensure that the pipes and fittings are tested against the relevant British Standard as listed on WSD webpage. For (c), please note that this Authority will accept laboratories accredited by the Hong Kong Laboratory Accreditation Scheme (HOKLAS) under the following sub-categories:-

Category	Sub-category
Construction Materials	(i) Metallic materials
	(ii) Pipes
	(iii) Showers
	(iv) Tapwares and valves

If the submission is accepted, the WSD will include the product in its pre-approved list. Builders can use the product in plumbing projects before the GA expiry date of that product (the validity is a maximum period of five years).

The above requirements are tabulated below:

Table B2.1.1.1 Applicable materials for fresh water and salt water inside service at different locations

Pipe/ Pipe fitting material	Fresh Water Inside Service		Salt Water Inside Service ⁽¹⁾
	Cold Water	Hot Water	
Copper	✓	✓	✗
Ductile iron (with internal coating)	✓	✓	✓
Polyethylene (PE)	✓	/	✓ ⁽²⁾
Polyethylene-cross-linked (PE-X)	✓	✓	✗
Plastic lined steel (PVC-C lining)	✓	✗	✗
Plastic lined steel (PVC-U/ PE lining)	✓	✗	✗
Polyvinyl chloride - chlorinated (PVC-C)	✓	✓	✗
Polyvinyl chloride - unplasticized (PVC-U)	✓	/	✓
Stainless steel	✓	✓	✗

✓ : Suitable for use when the relevant standards are complied with in general

✗ : Not suitable for use in general

(1) : Suitable location(s) for installation may refer to fresh water inside service

(2) : When installed in exposed condition, black pipe and pipe fittings shall be used.

Table B2.1.1.2 Applicable materials for fire service at different locations

Pipe/ Pipe fitting material	Fire service	
	Fresh water	Salt water
Copper	✓	✗
Ductile iron	✓	✓
Galvanized steel	✓	✗
Stainless steel	✓	✗
Polyvinyl chloride - chlorinated (PVC-C)	✗	✓

✓ : Suitable for use when the relevant standards are complied with in general

✗ : Not suitable for use in general

Table B2.1.1.3 Fitting materials for inside service and fire service

Valve/Strainer component materials	Fresh water inside service		Salt water inside service	Fire service	
	Cold water	Hot water		Fresh water	Salt water
<i>A. Body and bonnet</i>					
Cast iron (with internal coating)*	✓	✓	✓	✓	✓
Copper alloy – brass**	✓	✓	✗	✓	✗
Copper alloy – dezincification resistant (DZR) brass (e.g. CW602N/CZ132)	✓	✓	✗	✓	✗
Copper alloy – bronze (gunmetal)	✓	✓	✓	✓	✓
Ductile iron (with internal coating)*	✓	✓	✓	✓	✓
Polyethylene (PE)	✓	✗	✓	✗	✗
Polyvinyl chloride - unplasticized (PVC-U)	✗	✗	✓	✗	✗
Stainless steel (Grade 304)	✓	✓	✗	✓	✗
Stainless steel (Grade 316)	✓	✓	✗	✓	✗
Duplex Stainless steel (Grade 1.4462 or superior)	✓	✓	✓	✓	✓

Table B2.1.1.3 Fitting materials for inside service and fire service

Valve/Strainer component materials	Fresh water inside service		Salt water inside service	Fire service	
	Cold water	Hot water		Fresh water	Salt water
<i>B. Stem/ shaft</i>					
Copper alloy – brass**	✓	✓	✗	✓	✓
Copper alloy – dezincification resistant (DZR) brass	✓	✓	✓	✓	✓
Copper alloy – bronze (gunmetal)	✓	✓	✓	✓	✓
Stainless steel (Grade 304)	✓	✓	✗	✓	✗
Stainless steel (Grade 316)	✓	✓	✓	✓	✓
Stainless steel (Grade 431)	✓	N/A	✗	✓	✓
Polyvinyl chloride - unplasticized (PVC-U)	✗	✗	✓	✗	✗
<i>C. Wedge (in gate valves etc.)</i>					
Ductile iron (with coating)*	✓	✓	✓	✓	✓
Resilient material to BS EN 681-1, Type WA (elastomeric seals)*	✓	✓	✓	✓	✓
Stainless steel (Grade 304)	✓	✓	✗	✓	✗
Stainless steel (Grade 316)	✓	✓	✓	✓	✓
<i>D. Seat and disc</i>					
Copper alloy – brass**	✓	✓	✓	✓	✓
Copper alloy – dezincification resistant (DZR) brass	✓	✓	✓	✓	✓
Copper alloy – bronze (gunmetal)	✓	✓	✓	✓	✓
Polyvinyl chloride - unplasticized (PVC-U)	✗	✗	✓	✗	✗
Resilient material to BS EN 681-1, Type WA (elastomeric seals)*	✓	✓	✓	✓	✓
Stainless steel (Grade 304)	✓	✓	✗	✓	✗
Stainless steel (Grade 316)	✓	✓	✓	✓	✓
<i>E. Bolt, Nut & Washer</i>					
Steel	✓	✓	✗	✓	✗
Stainless steel (Grade 304)	✓	✓	✗***	✓	✗
Stainless steel (Grade 316)	✓	✓	✓	✓	✓
<i>F. Cap (disc)/ spring (non-return valve)</i>					
Copper alloy	✓	✓	✓	✓	✓
Ductile iron (with coating)*	✓	✓	✓	✓	✓
Stainless steel (Grade 304)	✓	✓	✗	✓	✗
Stainless steel (Grade 316)	✓	✓	✓	✓	✓

Table B2.1.1.3 Fitting materials for inside service and fire service

Valve/Strainer component materials	Fresh water inside service		Salt water inside service	Fire service	
	Cold water	Hot water		Fresh water	Salt water
<i>G. Screen (strainers)</i>					
Stainless steel (Grade 304)	✓	✓	✗	✓	✗
Stainless steel (Grade 316)	✓	✓	✓	✓	✓
<i>H. Drain plug (strainers)</i>					
Copper alloy – brass**	✓	✓	✓	✓	✓
Copper alloy – dezincification resistant (DZR) brass	✓	✓	✓	✓	✓
Copper alloy – bronze (gunmetal)	✓	✓	✓	✓	✓
Malleable iron (with coating)*	✓	✓	✓	✓	✓
<i>I. Lever (ball float valve)</i>					
Stainless steel (Grade 304)	✓	✓	✗	✓	✗
Stainless steel (Grade 316)	✓	✓	✓	✓	✓
Copper alloy – brass**	✓	✓	✓	✓	✓
Copper alloy – dezincification resistant (DZR) brass	✓	✓	✓	✓	✓
Copper alloy – bronze (gunmetal)	✓	✓	✓	✓	✓

* Coating material e.g. epoxy shall comply with BS 6920:2014 for respective cold water and/or hot water applications.

** Except brass containing zinc of more than 15% by mass as it will be susceptible to dezincification.

*** For Bolt, Nut & Washer that do not have any contact with salt water, the material can be Stainless Steel (Grade 304)

B2.2 ‘General Acceptance*’ (‘GA*’) Scheme (Voluntary)

B2.2.1 The GA* Scheme promotes adoption of low metal leaching rate metallic plumbing products in fresh water inside service application. For scheme details, please refer to:-

http://www.wsd.gov.hk/filemanager/common/licensed_plumbers/ga_star_scheme_e.pdf

B2.2.2 The GA* Scheme covers but not limited to the following plumbing products:-

- Pipes and pipe fittings (stainless steel, copper or copper alloy);
- Valves;
- Strainers;
- Expansion/settlement/flexible joints; and
- Taps and mixers.

- B2.2.3 Only metallic plumbing products with valid GA are eligible to apply for the GA* Scheme.
- B2.2.4 Low metal leaching rate metallic plumbing products under the GA* Scheme shall possess supporting document/test report to prove compliance with an Australian/New Zealand Standard AS/NZS 4020.
- B2.2.5 For a particular model of plumbing product designed with different connection size/diameter, compliant metal leaching test conducted on the smallest size/diameter fitting is sufficed for the whole range of size/diameter of that model of plumbing product as stated in the GA letter.
- B2.2.6 Any product, or part of a product, installed within 250mL draw-off of a drinking water delivery point shall be classified as ‘end-of-line’ fitting. ‘End-of-line’ fitting shall comply with the extraction of metals procedure for testing in Appendix I of AS/NZS 4020.
- B2.2.7 Procedures for testing ‘in-line’ fittings shall comply with the stipulations in Appendix H of AS/NZS 4020.
- B2.2.8 The results of heavy metal concentrations from tests for ‘in-line’ fittings shall be multiplied by appropriate Scaling Factors.
- B2.2.9 Scaling Factor is not applicable for ‘end-of-line’ fittings.
- B2.2.10 Scaling Factors for ‘in-line’ fittings are tabulated in Table B2.2.10.1:-

Table B2.2.10.1 Scaling Factors for various plumbing products

In-line Metallic Plumbing Product	Scaling Factor
Pipes	1 (Nil)
Pipe fittings	0.05
Gate valves, globe valves and ball valves	0.01
Butterfly valves	0.05
Non-return/check valves and pressure reducing valves	0.01 for DN \geq 100mm 0.05 for DN<100mm
Strainer	0.10
Expansion/settlement/flexible joint	0.01

- B2.2.11 For test reports issued by laboratories under the MRA with HOKLAS, adjustment on the final metal concentration by using the Scaling Factors above may be necessary before acceptance of the products by the WSD.

B2.3 Leaching Test for General Acceptance (GA) Application of Taps and Mixers - Alternative Route

- B2.3.1 The taps and mixers shall have certification or test reports from either B.S.Kitemark, WRAS or accredited laboratories acceptable to WA.
- B2.3.2 The leaching test of taps and mixers shall follow the testing requirements specified in Appendix H or I of Australian/New Zealand Standard AS/NZS 4020:2018 at a testing temperature (20±2)°C. The maximum allowable concentration of heavy metals of the extracts shall comply with the latest Hong Kong Drinking Water Standards (HKDWS).
- B2.3.3 The taps and mixers shall follow, except for chemical composition test, the current requirements as detailed in Table B7 of TR.
- B2.3.4 The material grades of metallic components of taps and mixers shall be specified in test reports. The material grade of respective component shall comply with BS EN 1982:2008, BS EN 12420:2014, BS EN 12163:2016, BS EN 12164:2016, BS EN 12165:2016, BS EN 12167:2016, BS EN 10088-1:2014, BS EN 10088-2:2014, BS EN 10088-3: 2014, BS EN 10283:2010 or updated version of the above-mentioned standards where appropriate.
- B2.3.5 As usual, it is required to declare in the GA application form that the sample provided for testing and certification by any accredited testing agent is the representative sample of the model submitted for GA application and all such GA products manufactured shall be replicas of that sample, without modifications or change of specified materials of construction.
- B2.3.6 Under surveillance programme, the WSD will randomly take samples of different types of plumbing products with valid GA to test for compliance with the statutory requirements. The samples will be acquired from a number of sources including retailed shops, warehouses and other venues as advised by GA applicants for the WSD's selection.

B3. Review of Standards and Requirements

- B3.1 The WA regularly reviews the standards and requirements stipulated for water pipes, fittings and components to allow for innovation and changes in technology and to ensure relevance.
- B3.2 If standards for a plumbing material component are not stipulated in this TR, WA shall be approached to confirm the necessary standards and requirements for compliance.

B4. General Conditions for All Pipes, Fittings and Components for Use in Inside Service

- B4.1 All pipes, fittings and components installed as Inside Service and/or Fire Service shall comply with the conditions in this TR where applicable.
- B4.2 The details below shall be clearly shown in all pipes, fittings and components where applicable:-
- (a) Body marking showing manufacturer's logo and/or brand name on product body;
 - (b) Marking showing the Industrial Standard(s), e.g. BS EN 1057 for copper pipes; and
 - (c) Marking showing nominal size and direction of flow.
- B4.3 All non-metallic materials and products, that, when used, may come into contact with water intended for human consumption must comply with all relevant requirements in BS 6920-1:2014, BS 6920-2.1:2014, BS 6920-2.2.1:2000+A3:2014, BS 6920-2.2.2:2000+A1:2014, BS 6920-2.2.3:2000+A2:2014, BS 6920-2.3:2000+A1:2014, BS 6920-2.4:2000+A1:2014, BS 6920-2.5:2000+A2:2014, BS 6920-2.6:2000+A2:2014 and BS 6920-3:2000.
- B4.4 Non-metallic materials, intended for use in cold water supply systems, shall be suitable for use up to the maximum water temperature of 35 °C and tested to this concerned temperature under the BS 6920 series. For non-metallic materials intended for use in hot water supply systems, the test temperature for High Temperature Tests shall conform to stipulations in BS 6920:2014.
- B4.5 The non-metallic materials shall only be installed in a potable water supply system with a water temperature not exceeding the test temperature of the High

Temperature Tests.

- B4.6 All pipes, fittings and components shall comply with all relevant statutory requirement and the Standards stipulated by the WA.

B5. Pipes and Pipe Fittings

Category	Copper Pipes and Fittings
Type	Copper Pipes
Prescribed Specification in WWR	BS EN 1057:2006+A1:2010 Copper and copper alloys – Seamless, round copper tubes for water and gas in sanitary and heating applications
Test item(s)	<ul style="list-style-type: none"> • Dimension - (Clause 7.3) • Hydrostatic test - (Clause 10.9 and Annex C2) • Tensile test - (Clause 10.2) • Hardness test - (Clause 10.3) • Bending test - (Clause 10.6) • Drift expanding test - (Clause 10.7) • Carbon Content test - (Clause 10.4) / Carbon film test - (Clause 10.5) • Chemical composition - (Clause 7.1)

Category	Copper Pipes and Fittings
Type	Copper Pipes
Prescribed Specification in WWR	BS EN 12449:2016 Copper and copper alloys. Seamless, round tubes for general purposes
Test item(s)	<ul style="list-style-type: none"> • Dimension - (Clause 6.3) • Hydrostatic test - (Clause 8.5) • Tensile test - (Clause 8.2) • Hardness test - (Clause 8.3) • Drift expanding test - (Clause 8.4.1) • Chemical composition - (Clause 6.1)

Category	Copper Pipes and Fittings
Type	Copper Fittings
Prescribed Specification in WWR	BS EN 1254-1:1998 Fittings with ends for capillary soldering or capillary brazing to copper tubes
Test item(s)	<ul style="list-style-type: none"> • Dimension - (Clause 4.3) • Leaktightness under internal hydrostatic pressure - (Clause 4.6.1) • Resistance to stress corrosion - (Clause 4.6.2) • Carbon content test - (Clause 4.5.2) / Carbon film test - (Clause 4.5.2) • Chemical composition - (Clause 4.2)

Category	Copper Pipes and Fittings
Type	Copper Fittings
Prescribed Specification in WWR	BS EN 1254-2:1998 Fittings with compression ends for uses with copper tubes
Test item(s)	<ul style="list-style-type: none"> • Dimension - (Clause 4.3) • Leaktightness under internal hydrostatic pressure - (Clause 4.6.1) • Resistance to stress corrosion - (Clause 4.6.4) • Resistance to pull-out - (Clause 4.6.2) • Leaktightness under internal hydrostatic pressure whilst subjected to bending - (Clause 4.6.3) • Chemical composition - (Clause 4.2)

Category	Copper Pipes and Fittings
Type	Copper Fittings
Prescribed Specification in WWR	BS EN 1254-5:1998 Fittings with short ends for capillary brazing to copper tubes
Test item(s)	<ul style="list-style-type: none"> • Dimension - (Clause 4.3) • Leaktightness under internal hydrostatic pressure - (Clause 4.6.1) • Resistance to stress corrosion - (Clause 4.6.2) • Carbon content test - (Clause 4.5.2) / Carbon film test - (Clause 4.5.2) • Chemical composition - (Clause 4.2)

Category	Copper Pipes and Fittings
Type	Copper Fittings
Prescribed Specification in WWR	BS EN 1254-6:2012 Copper and copper alloys. Plumbing fittings. Fittings with push-fit ends
Test item(s)	<ul style="list-style-type: none"> • Dimension - (Clause 4.3) • Leaktightness under internal hydrostatic pressure - (Clause 5.1.4) • Resistance to stress corrosion - (Clause 5.1.14) • Resistance to pull-out - (Clause 5.1.5) • Leaktightness under internal hydrostatic pressure whilst subjected to bending - (Clause 5.1.10) • Chemical composition - (Clause 4.2)

Category	Copper Pipes and Fittings
Type	Copper Fittings
Prescribed Specification in WWR	BS 8537:2010 Copper and copper alloys Plumbing fittings - Specification for press ends of plumbing fittings for use with metallic tubes
Test item(s)	<ul style="list-style-type: none"> • Dimension - (Clause 6.2) • Leaktightness under internal hydrostatic pressure - (Clause 8.4.1) • Resistance to pull-out - (Clause 8.4.2) • Resistance of joints with tubes to pressure cycling - (Clause 8.4.5) • Resistance of joints and tube to vibration - (Clause 8.4.7) • Resistance of joints to static flexural force - (Clause 8.4.8) • Resistance to stress corrosion - (Clause 8.4.10) • Chemical composition - (Clause 6.1)

Category	Stainless Steel Pipes and Fittings
Type	Stainless Steel Pipes
Prescribed Specification in WWR	BS EN 10312:2002 Welded stainless steel tubes for the conveyance of water and other aqueous liquids – Technical delivery conditions
Test item(s)	<ul style="list-style-type: none"> • Dimension - (Clause 8.8) • Hydrostatic test - (Clause 11.4.3) • Tensile test - (Clause 11.1) • Drift expanding test - (Clause 11.2) • Flattening test - (Clause 11.3) • Intergranular corrosion test (if applicable) - (Clause 11.8/ BS EN ISO 3651-2:1998) • Chemical composition - (Clause 7)

Category	Stainless Steel Pipes and Fittings
Type	Stainless Steel Pipes
Prescribed Specification in WWR	BS EN 10217-7:2014 Welded steel tubes for pressure purposes. Technical delivery conditions Stainless steel tubes
Test item(s)	<ul style="list-style-type: none"> • Dimension - (Clause 8.8) • Hydrostatic test - (Clause 11.8.1) • Tensile test - (Clause 11.2.1) • Drift expanding test - (Clause 11.4.4) • Flattening test - (Clause 11.4.2) • Intergranular corrosion test (if applicable) - (Clause 11.7) • Chemical composition - (Clause 8.2)

Category	Stainless Steel Pipes and Fittings
Type	Stainless Steel Pipes
Prescribed Specification in WWR	BS 6362:1990 Specification for stainless steel tubes suitable for screwing in accordance with BS21 “Pipe threads for tubes and fittings where pressure-tight joints are made on the threads”
Test item(s)	<ul style="list-style-type: none"> • Dimension-Including Straightness & Preparation end - (Clause 7) • Leak tightness - (Clause 9.4) • Tensile test - (Clause 9.3) • Chemical composition - (Clause 5)

Category	Stainless Steel Pipes and Fittings
Type	Stainless Steel Fittings
Prescribed Specification in WWR	AS 3688:2016 Water supply and gas systems - Metallic fittings and end connectors
Concerned Sections	
Stainless Steel Compression Fittings (AS 3688:2016 - Section 6)	
Test item(s)	<ul style="list-style-type: none"> • Dimensions (Manufacture requirement) - (Clause 3) • Leaktightness under internal pressure test - (Clause 4.2 and Appendix D) • Strength of joint assembly (pressure cycling test) - (Clause 4.4 and Appendix F) • Resistance to pull-out of assembled joints - (Clause 4.5 and Appendix G) • Chemical composition - (BS EN 10088-1:2014) • Intergranular corrosion test (if applicable) - (BS EN ISO 3651-2:1998)
Stainless Steel Roll-Grooved Jointing End Connectors And Coupling Body (AS 3688:2006 - Section 9)	
Test item(s)	<ul style="list-style-type: none"> • Dimensions (Manufacture requirement) - (Clause 3) • Leaktightness under internal pressure test - (Clause 4.2 and Appendix D) • Strength of joint assembly (pressure cycling test) - (Clause 4.4 and Appendix F) • Resistance to pull-out of assembled joints - (Clause 4.5 and Appendix G) • Leaktightness under internal hydrostatic pressure whilst subjected to bending - (Clause 4.7 and Appendix I) • Roll-grooved assembly (Joint pressure resistance) - (Clause 4.9 and Appendix K) • Chemical composition - (BS EN 10088-1:2014) • Intergranular corrosion test (if applicable) - (BS EN ISO 3651-2:1998)

Category	Stainless Steel Pipes and Fittings
Type	Stainless Steel Fittings
Prescribed Specification in WWR	AS 3688:2016 Water supply and gas systems - Metallic fittings and end connectors
Stainless Steel Mechanical Jointing Press - Fit End Connectors (AS 3688: 2016 - Section 10)	
Test item(s)	<ul style="list-style-type: none"> • Dimensions (Manufacture requirement) - (Clause 3) • Leaktightness under internal pressure test - (Clause 4.2 and Appendix D) • Strength of joint assembly (pressure cycling test) - (Clause 4.4 and Appendix F) • Resistance to pull-out of assembled joints - (Clause 4.5 and Appendix G) • Leaktightness under internal hydrostatic pressure whilst subjected to bending - (Clause 4.7 and Appendix I) • Compatibility of water fittings with pipe - (Clause 4.8 and Appendix J) • Resistance of press fitting joints and tubes to vibration - (Clause 4.13 and Appendix P) • Chemical composition - (BS EN 10088-1:2014) • Intergranular corrosion test (if applicable) - (BS EN ISO 3651-2:1998)

Category	Ductile Iron Pipes and Fittings
Type	Ductile Iron Pipes
Prescribed Specification in WWR	BS EN 545:2010 Ductile iron pipes, fittings, accessories and their joints for water pipelines. Requirements and test methods
Test item(s)	<ul style="list-style-type: none"> • Dimensions - (Clause 4.3) • Straightness of pipe - (Clause 4.3.4) • Leak tightness test - (Clause 6.5) • Tensile test - (Clause 6.3) • Brinell hardness - (Clause 6.4) • Coating thickness - (Clause 4.5)

Category	Ductile Iron Pipes and Fittings
Type	Ductile Iron Fittings
Prescribed Specification in WWR	BS EN 545:2010 Ductile iron pipes, fittings, accessories and their joints for water pipelines. Requirements and test methods
Test item(s)	<ul style="list-style-type: none"> • Dimensions - (Clause 4.3) • Leak tightness test - (Clause 6.5) • Tensile test - (Clause 6.3) • Coating thickness - (Clause 4.6)

Category	Galvanised Steel Pipes and Fittings
Type	Galvanised Steel Pipes
Prescribed Specification in WWR	BS EN 10255:2004+A1:2007 Non-alloy steel tubes suitable for welding and threading. Technical delivery conditions
Test item(s)	<ul style="list-style-type: none"> • Dimensions - (Clause 8.4) • Tensile test - (Clause 9.3) • Bend test - (Clause 9.4) • Flattening test - (Clause 9.5) • Leak tightness test - (Clause 9.6) • Chemical composition test - (Clause 8.2) • Coating thickness test (BS EN 10240:1998/ BS EN ISO 1461)

Category	Unplasticized Polyvinyl Chloride (PVC-U) Pipes and Fittings
Type	PVC-U Pipes
Prescribed Specification in WWR	BS EN ISO 1452-2:2009 Plastics piping systems for water supply and for buried and above-ground drainage and sewerage under pressure. Unplasticized poly(vinyl chloride) (PVC-U) – Pipe
Test item(s)	<ul style="list-style-type: none"> • Dimensions - (Clause 6) • Impact resistance - (Clause 8.1) • Resistance to internal pressure - (Clause 8.2)

Category	Unplasticized Polyvinyl Chloride (PVC-U) Pipes and Fittings
Type	PVC-U Fittings
Prescribed Specification in WWR	BS EN ISO 1452-3:2010 Plastics piping systems for water supply and for buried and above-ground drainage and sewerage under pressure. Unplasticized poly(vinyl chloride) (PVC-U) - Fittings
Test item(s)	<ul style="list-style-type: none"> • Dimensions - (Clause 6) • Resistance to internal pressure of fittings or parts of fittings - (Clause 8.1)

Category	Unplasticized Polyvinyl Chloride (PVC-U) Pipes and Fittings
Type	PVC-U Pipes
Prescribed Specification in WWR	BS 3505:1986 Specification for unplasticized polyvinyl chloride (PVC-U) pressure pipes for cold potable water
Test item(s)	<ul style="list-style-type: none"> • Dimension - (Clause 4) • Short-term hydrostatic pressure resistance - (Clause 6.4) • Impact resistance - (Clause 6.5)

Category	Chlorinated Polyvinyl Chloride (PVC-C) Pipes and Fittings
Type	PVC-C Pipes
Prescribed Specification in WWR	BS EN ISO 15877-2:2009 +A1:2010 Plastics piping systems for hot and cold water installations. Chlorinated poly(vinyl chloride) (PVC-C) – Pipes
Test item(s)	<ul style="list-style-type: none"> • Dimensions - (Clause 6) • Resistance to internal pressure - (Clause 7.1)

Category	Chlorinated Polyvinyl Chloride (PVC-C) Pipes and Fittings
Type	PVC-C Fittings
Prescribed Specification in WWR	BS EN ISO 15877-3:2009 +A1:2010 Plastics piping systems for hot and cold water installations. Chlorinated poly(vinyl chloride) (PVC-C) – Fittings
Test item(s)	<ul style="list-style-type: none"> • Dimensions - (Clause 6) • Resistance to internal pressure - (Clause 7.1)

Category	Crosslinked Polyethylene (PE-X) Pipes and Fittings
Type	PE-X Pipes
Prescribed Specification in WWR	BS 7291-3:2010 Thermoplastics pipe and fitting systems for hot and cold water for domestic purposes and heating installations in buildings. Specification for crosslinked polyethylene (PE-X) pipes and associated fittings
Test item(s)	<ul style="list-style-type: none"> • Dimensions - (Clause 4.1) • Short-term hydrostatic pressure resistance - (Clause 4.2.2)

Category	Crosslinked Polyethylene (PE-X) Pipes and Fittings
Type	PE-X Fittings
Prescribed Specification in WWR	BS 7291-3:2010 Thermoplastics pipe and fitting systems for hot and cold water for domestic purposes and heating installations in buildings. Specification for crosslinked polyethylene (PE-X) pipes and associated fittings
Test item(s)	<ul style="list-style-type: none"> • Dimensions - (Clause 4.1) • Short-term hydrostatic pressure resistance - (Clause 5.4.2)

Category	Polyethylene (PE) Pipes and Fittings
Type	PE Pipes
Prescribed Specification in WWR	BS EN 12201-2:2011 + A1:2013 Plastics piping systems for water supply, and for drainage and sewerage under pressure. Polyethylene (PE). Pipes
Test item(s)	<ul style="list-style-type: none"> • Dimensions - (Clause 6) • Hydrostatic strength - (Clause 7.2)

Category	Polyethylene (PE) Pipes and Fittings
Type	PE Fittings
Prescribed Specification in WWR	BS EN 12201-3:2011 + A1:2013 Plastics piping systems for water supply, and for drainage and sewerage under pressure. Polyethylene (PE). Fittings
Test item(s)	<ul style="list-style-type: none"> • Dimensions - (Clause 6) • Hydrostatic strength - (Clause 7.3)

Category	Pipes and Fittings
Type	Fittings (Long Screw Connector / Flange Adaptor for Water Meter)
Test item(s)	<ul style="list-style-type: none"> • Dimension - (Clause 3.2.1.2 of TR for Long Screw Connector; Based on Manufacturer Requirement for Flange Adaptor) • Chemical composition (body of long screw connector / flange adaptor) - (copper-zinc alloy, stainless steel or ductile iron with internal coating) • Coating thickness - (WIS 4-52-01 Appendix B)

Note:-

- 1) For non-metallic material in contact with fresh water intended for human consumption, the materials shall comply with the relevant requirements in BS 6920:2014.

B6. Valves

Category	Valve
Type	Flushing Valve
Prescribed Specification in WWR	BS EN 997:2012+A1:2015 WC pans and WC suites with integral trap
Test item(s)	<ul style="list-style-type: none"> • Dimensions - (Based on Manufacturer Requirement) • Flush volume - (Clause 6.5) • Flush rate - (Clause 6.6) • Physical endurance and leakage of flushing device - (Clause 6.7)

Category	Valve
Type	Gate Valve (Copper Alloy Body)
Prescribed Specification in WWR	BS EN 12288:2010 Industrial valves. Copper alloy gate valves
Test item(s)	<ul style="list-style-type: none"> • Dimensions - (Clause 4.2.4) • Pressure test - (Clause 5.1) • Chemical composition - (Clause 4.2.2) (for components: body, bonnet, seat, stem where applicable)

Category	Valve
Type	Gate Valve (Cast Iron Body/Ductile Iron Body)
Prescribed Specification in WWR	BS EN 1171:2015 Industrial valves. Cast iron gate valves
Test item(s)	<ul style="list-style-type: none"> • Dimensions - (Clause 4.1.3) • Pressure test - (Clause 5.1) • Strength torque - (Clause 4.3) • Coating thickness - (WIS 4-52 -01 Appendix B) • Tensile test - (BS EN 1563:2011 for Spheroidal graphite cast irons / BS EN 1561:2011 for Grey cast irons) • Chemical composition - (Clause 4.1.1) (for components: stem, stem nut, seat, seat ring where applicable)

Category	Valve
Type	Gate Valve (Cast Iron Body/Ductile Iron Body)
Prescribed Specification in WWR	<p>BS EN 1074-1:2000 Valves for water supply. Fitness for purpose requirements and appropriate verification tests. General requirements; and</p> <p>BS EN 1074-2:2000 Valves for water supply. Fitness for purpose requirements and appropriate verification tests. Isolating valves</p>
Test item(s)	<ul style="list-style-type: none"> • Dimensions - (Clause 4.6 of BS EN 1074-1:2000 & Clause 4.2 of BS 5163-1:2004) • Leak-tightness to internal pressure - (Clause 5.2.1.1) • Seat tightness at high differential pressure - (Clause 5.2.2.1) • Resistance of valves to operating loads (MST) - (Clause 5.1.4) • Coating thickness - (WIS 4-52 -01 Appendix B) • Tensile test - (BS EN 1563:2011 for Spheroidal graphite cast irons / BS EN 1561:2011 for Grey cast irons) • Chemical composition - (Clause 4.1.1) (for components: stem, stem nut, seat, seat ring where applicable)

Category	Valve
Type	Gate Valve (Steel Body)
Prescribed Specification in WWR	BS EN 1984:2010 Industrial valves. Steel gate valves
Test item(s)	<ul style="list-style-type: none"> • Dimensions - (Clause 4.1.3) • Pressure test - (Clause 5.1) • Chemical composition - (Clause 4.1.1) (for components: body, bonnet, stem, stem nut, seat, seat ring where applicable)

Category	Valve
Type	Check Valve (Copper Alloy Body)
Prescribed Specification in WWR	BS 5154:1991 Specification for copper alloy globe, globe stop and check, check and gate valves (Specification for gate valves replaced by BS EN 12288)
Test item(s)	<ul style="list-style-type: none"> • Dimensions - (Clause 8) • Pressure test requirement - (Clause 11) • Chemical composition - (Clause 10) (for components: body, bonnet, seat where applicable)

Category	Valve
Type	Check Valve (Cast Iron/Ductile Iron/Steel Body)
Prescribed Specification in WWR	BS EN 16767:2016 Industrial valves. Steel and cast iron check valves
Test item(s)	<ul style="list-style-type: none"> • Dimensions - (Clause 4.2.3) • Pressure test - (Clause 5.1) • Coating thickness - (WIS 4-52 -01 Appendix B) • Tensile test - (BS EN 1563:2011 for Spheroidal graphite cast irons / BS EN 1561:2011 for Grey cast irons) • Chemical composition - (Clause 4.2.1) (for components: disc, seat ring, stem where applicable)

Category	Valve
Type	Check Valve (Cast Iron/Ductile Iron Body)
Prescribed Specification in WWR	BS EN 12334:2001 Industrial valves. Cast iron check valves
Test item(s)	<ul style="list-style-type: none"> • Dimensions - (Clause 4.1.3) • Pressure test - (Clause 5.1) • Coating thickness - (WIS 4-52 -01 Appendix B) • Tensile test - (BS EN 1563:2011 for Spheroidal graphite cast irons / BS EN 1561:2011 for Grey cast irons) • Chemical composition - (Clause 4.1.1) (for components: disc, seat ring, stem where applicable)

Category	Valve
Type	Ball Valve (Copper Alloy Body)
Prescribed Specification in WWR	BS EN 13547:2013 Industrial valves. Copper alloy ball valves
Test item(s)	<ul style="list-style-type: none"> • Dimensions - (Clause 4.2.4) • Production pressure testing & seat leakage rate - (Clause 5.1 & 5.2) • Chemical composition - (Annex A) (for components: body, ball where applicable)

Category	Valve
Type	Ball Valve (Copper Alloy Body/Stainless Steel Body)
Prescribed Specification in WWR	BS EN 13828:2003 Building valves. Manually operated copper alloy and stainless steel ball valves for potable water supply in buildings. Tests and requirements
Test item(s)	<ul style="list-style-type: none"> • Dimensions - (Clause 5.2) • Hydraulic strength - (Clause 7.4.1 & 7.4.2) • Chemical composition - (Clause 5.1) (for components: body, ball where applicable)

Category	Valve
Type	Globe Valve (Copper Alloy Body)/ Check Valve (Copper Alloy Body)
Prescribed Specification in WWR	BS 5154:1991 Specification for copper alloy globe, globe stop and check, check and gate valves (Specification for gate valves replaced by BS EN 12288)
Test item(s)	<ul style="list-style-type: none"> • Dimensions - (Clause 8) • Pressure test requirement - (Clause 11) • Chemical composition - (Clause 10) (for components: body, bonnet, stem, seat where applicable)

Category	Valve
Type	Globe Valve (Steel Body)
Prescribed Specification in WWR	BS EN 13709:2010 Industrial valves. Steel globe and globe stop and check valves
Test item(s)	<ul style="list-style-type: none"> • Dimensions - (Clause 4.1.3) • Pressure test - (Clause 5.1) • Chemical composition - (Clause 4.1.1) (for components: body, bonnet, stem, seat where applicable)

Category	Valve
Type	Globe Valve (Cast Iron Body/Ductile Iron Body)
Prescribed Specification in WWR	BS EN 13789:2010 Industrial valves. Cast iron globe valves
Test item(s)	<ul style="list-style-type: none"> • Dimensions - (Clause 4.1.3) • Pressure test - (Clause 5.1) • Coating thickness - (WIS 4-52 -01 Appendix B) • Tensile test - (BS EN 1563:2011 for Spheroidal graphite cast irons / BS EN 1561:2011 for Grey cast irons) • Chemical composition - (Clause 4.1.1) (for components: seat, seat ring, stem where applicable)

Category	Valve
Type	Butterfly Valve
Prescribed Specification in WWR	BS EN 593:2009+A1:2011 Industrial valves. Metallic butterfly valves
Test item(s)	<ul style="list-style-type: none"> • Dimensions - (Clause 4.1.4) • Leak tightness - (Clause 4.2.4) • Coating thickness - (WIS 4-52 -01 Appendix B) • Tensile test - (BS EN 1563:2011 for Spheroidal graphite cast irons / BS EN 1561:2011 for Grey cast irons) • Chemical composition - (Clause 4.1.2) (for components: body, stem, seat where applicable)

Category	Valve
Type	Ball Float Valve
Prescribed Specification in WWR	BS 1212-1:1990 Specification for piston type float operated valves (copper alloy body) (excluding floats)
Test item(s)	<ul style="list-style-type: none"> • Dimensions - (Section 3) • Hydraulic pressure test - (Clause 24) • Shut-off test - (Clause 24) • Chemical composition - (for components: body, piston, lever where applicable)

Category	Valve
Type	Ball Float Valve
Prescribed Specification in WWR	BS 1212-2:1990 Float operated valves. Specification for diaphragm type float operated valves (copper alloy body) (excluding floats)
Test item(s)	<ul style="list-style-type: none"> • Dimensions - (Section 3) • Hydraulic pressure test - (Clause 26) • Shut-off test - (Clause 26) • Chemical composition - (for components: body, piston, lever where applicable)

Category	Valve
Type	Ball Float Valve
Prescribed Specification in WWR	BS 1212-3:1990 Specification for diaphragm type float operated valves (plastics bodied) for cold water services only (excluding floats)
Test item(s)	<ul style="list-style-type: none"> • Dimensions - (Section 3) • Hydraulic pressure test - (Clause 14.1) • Shut-off test - (Clause 14.2) • Backflow prevention test - (Clause 15) • Endurance test - (Clause 17)

Category	Valve
Type	Ball Float Valve
Prescribed Specification in WWR	BS 1212-4:2016 Specification for compact type float operated valves for WC flushing cisterns (including floats)
Test item(s)	<ul style="list-style-type: none"> • Dimensions - (Clause 5.1) • Static pressure test - (Clause 6.1.1) • Shut-off pressure test - (Clause 6.1.2) • Backflow prevention test - (Clause 6.2) • Endurance test - (Clause 6.4)

Category	Valve
Type	Pressure Reducing Valve
Prescribed Specification in WWR	BS EN 1567:1999 Building valves. Water pressure reducing valves and combination water reducing valves. Requirements and tests.
Test item(s)	<ul style="list-style-type: none"> • Dimensions - (Clause 4) • Pressure strength and tightness of the body - (Clause 8.2.2) • Flow rate and outlet pressure - (Clause 8.3.4) • Coating thickness - (WIS 4-52 -01 Appendix B) • Tensile test - (BS EN 1563:2011 for Spheroidal graphite cast irons / BS EN 1561:2011 for Grey cast irons) • Chemical composition - (Clause 6) (for components: body, seat where applicable)

Category	Valve
Type	Hydrant Valve (Fire Hydrant Systems)
Prescribed Specification in WWR	BS 5041-1:1987 Specification for landing valves for wet risers
Test item(s)	<ul style="list-style-type: none"> • Dimensions - (Clause 9 Figure 5a of BS 336:2010) • Hydraulic pressure test - (Clause 19) • Water flow rate and outlet pressure - (Clause 22) • Chemical composition - (Clause 8) (for components: body, bonnet, disc where applicable)

Category	Valve
Type	Valves (PVC-U)
Prescribed Specification in WWR	BS EN ISO 1452-4:2009 Plastics piping systems for water supply and for buried and above-ground drainage and sewerage under pressure. Unplasticized poly(vinyl chloride) (PVC-U). Valves
Test item(s)	<ul style="list-style-type: none"> • Dimensions - (Clause 6) • Mechanical characteristics - (Clause 8.1)

Category	Valve
Type	Valves (PE)
Prescribed Specification in WWR	BS EN 12201-4:2012 Plastics piping systems for water supply, and for drainage and sewerage under pressure. Polyethylene (PE). Valves
Test item(s)	<ul style="list-style-type: none"> • Dimensions - (Clause 6) • Mechanical characteristics - (Clause 7)

Note:-

- 1) For chemical composition test, the grade of material shall comply with BS EN 1982:2008, BS EN 12420:2014, BS EN 12163:2016, BS EN 12164:2016, BS EN 12165:2016, BS EN 12167:2016, BS EN 10088-1:2014, BS EN 10088-2:2014, BS EN 10088-3: 2014, BS EN 10283:2010 or updated version except those material grades specified by the prescribed specification in WWR.
- 2) For non-metallic material in contact with fresh water intended for human consumption, the materials shall comply with the relevant requirements in BS 6920:2014.
- 3) Apart from the prescribed components in the summary above, chemical composition test shall be applied to metallic material in contact with water for a particular product where applicable.

B7. Taps/Mixers

Category	Tap
Type	Single Tap/ Combination Tap
Prescribed Specification in WWR	BS EN 200:2008 Sanitary tapware. Single taps and combination taps for water supply systems of type 1 and type 2. General technical specification
Test item(s)	<ul style="list-style-type: none"> • Dimensions - (Clause 6) • Leaktightness characteristics - (Clause 8.3 & 8.4) • Pressure resistance characteristics - (Clause 9.4 & 9.5) • Determination of flow Rate - (Clause 10) • Chemical composition (for components: body, spout where applicable) • Extraction of Metals from the Valve Cartridge (Non-metallic) • Visual Inspection of Electroplating Material

Category	Tap/Mixer
Type	Basin Mixing Valve/ Sink Mixing Valve/ Shower Mixing Valve/ Bath Mixing Valve/ Combination Draw-off Tap
Prescribed Specification in WWR	BS EN 1286:1999 Sanitary tapware. Low pressure mechanical mixing valves. General technical specifications
Test item(s)	<ul style="list-style-type: none"> • Dimensions - (Clause 8) • Leaktightness of the mixing valve - (Clause 9.3, 9.4 & 9.5) • Determination of flow rate - (Clause 10.5) • Chemical composition (for components: body, spout where applicable) • Extraction of Metals from the Valve Cartridge (Non-metallic) • Visual Inspection of Electroplating Material

Category	Thermostatic Mixing Valve
Type	Shower Mixing Valve/ Bath Mixing Valve
Prescribed Specification in WWR	BS EN 1287:1999 Sanitary tapware. Low pressure thermostatic mixing valves. General technical specifications
Test item(s)	<ul style="list-style-type: none"> • Dimensions - (Clause 8) • Leaktightness of the mixing valve - (Clause 9.3, 9.4 & 9.5) • Determination of flow rate - (Clause 10.5) • Sensitivity – (Clause 10.6) • Safety with cold water failure - (Clause 10.7) • Temperature stability with changing inlet pressure - (Clause 10.8) • Temperature stability with changing inlet temperature - (Clause 10.9) • Mechanical performance of the thermostatic mixing valve upstream of the obturator - Obturator in the closed position - (Clause 11.3) • Chemical composition (for components: body, spout where applicable) • Extraction of Metals from the Valve Cartridge (Non-metallic) • Visual Inspection of Electroplating Material

Category	Tap/Flushing Valve
Type	Sensor Mixing Valve/ Sensor Draw-off Tap/ Sensor Flushing Valve
Prescribed Specification in WWR	BS EN 15091:2013 Sanitary tapware. Electronic opening and closing sanitary tapware
Test item(s)	<ul style="list-style-type: none"> • Dimension - (Clause 5.2 / 6.5 / 7.4) • Leaktightness of the mixing valve - (Clause 4.6.4 & 4.6.5) • Pressure resistance characteristics - (Clause 4.7) • Hydraulic characteristics - (Clause 5.3 / 6.6 / 7.5) • Endurance test - (Clause 5.5 / 6.8 / 7.7) • Chemical composition (for components: body, spout where applicable) • Extraction of Metals from the Valve Cartridge (Non-metallic) • Visual Inspection of Electroplating Material

Category	Tap
Type	Self-Closing Draw-off Tap (Non-electronic)
Prescribed Specification in WWR	BS EN 816:1997 Sanitary tapware. Automatic shut-off valves PN 10
Test item(s)	<ul style="list-style-type: none"> • Dimensions - (Clause 8) • Leaktightness of the mixing valve - (Clause 9.2.2 & 9.2.3) • Flow rate (Clause 11.4.1) • Hydraulic characteristics - (Clause 11.4.1, 11.4.2 & 11.4.3) • Pressure resistance characteristics - (Clause 10.2.2 & 10.2.3) • Mechanical endurance or wear resistance characteristics - (Clause 13) • Chemical composition (for components: body, spout where applicable) • Extraction of Metals from the Valve Cartridge (Non-metallic) • Visual Inspection of Electroplating Material

Note:-

- 1) For chemical composition test, the grade of material shall comply with BS EN 1982:2008, BS EN 12420:2014, BS EN 12163:2016, BS EN 12164:2016, BS EN 12165:2016, BS EN 12167:2016, BS EN 10088-1:2014, BS EN 10088-2:2014, BS EN 10088-3: 2014, BS EN 10283:2010 or updated version except those material grades specified by the prescribed specification in WWR.
- 2) For non-metallic material in contact with fresh water intended for human consumption, the materials shall comply with the relevant requirements in BS 6920:2014.
- 3) Apart from the prescribed components in the summary above, chemical composition test shall be applied to metallic material in contact with water for a particular product where applicable.
- 4) The minimum flow rate requirements specified in the relevant prescribed specification for the draw-off taps, single and combination taps in table above are waived.
- 5) Visual Inspection of Electroplating Material - The samples shall be tested against Appendix I of AS/NZS 4020 for the metal leached from electroplating material (Cr & Ni) to quantify the health risk.

B8. Products covered by Water Efficiency Labelling Scheme (WELS)

B8.1 Showers for Bathing	
Applicable Standard(s)	Test(s)
<i>The latest version of the Scheme Document 'The Voluntary Water Efficiency Labelling Scheme on Showers for Bathing', published by WSD</i>	<ul style="list-style-type: none"> • Full compliance, in particular:- <ul style="list-style-type: none"> - Annex 1
AS/NZS 3662 (Performance of showers for bathing)	<ul style="list-style-type: none"> • Full compliance
Remarks: Products shall comply with Waterworks Ordinance (Chapter 102), Waterworks Regulations (Chapter 102A) and this Technical Requirements, including but not limited to relevant clauses of the General Conditions stated in Part B of this Technical Requirements.	

B8.2 Water Taps	
Applicable Standard(s)	Test(s)
<i>The latest version of the Scheme Document 'The Voluntary Water Efficiency Labelling Scheme on Water Taps', published by WSD</i>	<ul style="list-style-type: none"> • Full compliance, in particular:- <ul style="list-style-type: none"> - Annex 1
AS/NZS 3718 (Water Supply – Tap Ware)	<ul style="list-style-type: none"> • Full compliance
Remarks: Products shall comply with Waterworks Ordinance (Chapter 102), Waterworks Regulations (Chapter 102A) and this Technical Requirements, including but not limited to relevant clauses of the General Conditions stated in Part B of this Technical Requirements.	

B8.3 Washing Machines	
Applicable Standard(s)	Test(s)
<i>The latest version of the Scheme Document 'The Voluntary Water Efficiency Labelling Scheme on Washing Machines', published by WSD</i>	<ul style="list-style-type: none"> • Full compliance
Remarks: Products shall comply with this Technical Requirements, including but not limited to relevant clauses of the General Conditions stated in Part B of this Technical Requirements.	

B8.4 Urinal Equipment	
Applicable Standard(s)	Test(s)
<i>The latest version of the Scheme Document 'The Voluntary Water Efficiency Labelling Scheme on Urinal Equipment', published by WSD</i>	<ul style="list-style-type: none"> • Full compliance, in particular:- <ul style="list-style-type: none"> - Annex 1
ASME A112.19.2 (Ceramic plumbing fixtures)	<ul style="list-style-type: none"> • Full compliance
AS/NZS 3982 (Urinals)	<ul style="list-style-type: none"> • Appendix D
Testing requirements in conformity with Waterworks Ordinance and Waterworks Regulations (Urinal Flushing Valves)	<ul style="list-style-type: none"> • Full compliance
Remarks: Products shall comply with Waterworks Ordinance (Chapter 102), Waterworks Regulations (Chapter 102A) and this Technical Requirements, including but not limited to relevant clauses of the General Conditions stated in Part B of this Technical Requirements.	

B8.5 Flow Controllers	
Applicable Standard(s)	Test(s)
<i>The latest version of the Scheme Document 'The Voluntary Water Efficiency Labelling Scheme on Flow Controllers', published by WSD</i>	<ul style="list-style-type: none"> • Full compliance, in particular:- <ul style="list-style-type: none"> - Annex 1
AS 5200.037.2 (Flow controllers for use with heated or cold water systems)	<ul style="list-style-type: none"> • Full compliance
Remarks: Products shall comply with this Technical Requirements, including but not limited to relevant clauses of the General Conditions stated in Part B of this Technical Requirements.	

B9. Other Materials

Category	Others
Type	Expansion Joint / Settlement Joint / Flexible Joint / Rubber Joint
Prescribed Specification in WWR	BS EN 12266-1:2012 Industrial valves. Testing of metallic valves Pressure tests, test procedures and acceptance criteria. Mandatory requirements
Test item(s)	<ul style="list-style-type: none"> • Dimensions - (Based on Manufacturer Requirement) • Shell tightness to internal pressure - (BS EN 12266-1:2012) • Coating thickness - (WIS 4-52 -01 Appendix B) • Tensile test - (BS EN 1563:2011 for Spheroidal graphite cast irons / BS EN 1561:2011 for Grey cast irons) • Chemical composition - (for components: body, inner sleeve where applicable)

Category	Others
Type	Strainer
Prescribed Specification in WWR	BS EN 12266-1:2012 Industrial valves. Testing of metallic valves Pressure tests, test procedures and acceptance criteria. Mandatory requirements
Test item(s)	<ul style="list-style-type: none"> • Dimensions - (Based on Manufacturer Requirement) • Shell tightness to internal pressure - (BS EN 12266-1:2012) • Coating thickness - (WIS 4-52 -01 Appendix B) • Tensile test - (BS EN 1563:2011 for Spheroidal graphite cast irons / BS EN 1561:2011 for Grey cast irons) • Chemical composition - (for components: body, inner sleeve where applicable)

Category	Electric Water Heater
Type	Instantaneous electric water heater
Prescribed Specification in WWR	Waterworks Regulations (Cap.102A) – Schedule 2 Part 4 2(a)
Test item(s)	<ul style="list-style-type: none"> • it has been tested satisfactorily at factory to a pressure at least 1.5 times the maximum static working pressure of the water heater

Category	Gas Water Heater
Type	Instantaneous gas water heater
Prescribed Specification in WWR	Waterworks Regulations (Cap.102A) – Schedule 2 Part 4 2(a)
Test item(s)	<ul style="list-style-type: none"> • it has been tested satisfactorily at factory to a pressure at least 1.5 times the maximum static working pressure of the water heater

Category	Non-metallic material
Type	Non-metallic material (e.g. GRP panel, resin coating, epoxy coating)
Prescribed Specification in WWR	BS 6920:2014 Suitability of non-metallic products for use in contact with water intended for human consumption with regard to their effect on the quality of the water
Test item(s)	<ul style="list-style-type: none"> • Odour and flavour of water - (BS 6920:Section 2.2:2014) • Appearance of water - (BS 6920:Section 2.3:2014) • Growth of aquatic microorganisms - (BS 6920:Section 2.4:2014) • The extraction of substances that may be of concern to public health - (BS 6920:Section 2.5:2014) • The extraction of metals - (BS 6920:Section 2.6:2014) • High Temperature Test - (BS 6920:Part 3:2000)

Category	Lining materials of potable water tanks
Type	Tile Grout, Paint/Coating & Cementitious Products
Prescribed Specification in WWR	BS 6920:2014 Suitability of non-metallic products for use in contact with water intended for human consumption with regard to their effect on the quality of the water
Test item(s)	<ul style="list-style-type: none"> • Odour and flavour of water - (BS 6920:Section 2.2:2014) • Appearance of water - (BS 6920:Section 2.3:2014) • Growth of aquatic microorganisms - (BS 6920:Section 2.4:2014) • The extraction of substances that may be of concern to public health - (BS 6920:Section 2.5:2014) • The extraction of metals - (BS 6920:Section 2.6:2014) • High Temperature Test - (BS 6920:Part 3:2000)

Category	Lining materials of potable water tanks
Type	Tile
Prescribed Specification in WWR	BS 6920:2014 Suitability of non-metallic products for use in contact with water intended for human consumption with regard to their effect on the quality of the water
Test item(s)	<ul style="list-style-type: none"> • The extraction of metals - (BS 6920:Section 2.6:2014) • High Temperature Test - (BS 6920:Part 3:2000)

Category	Soldering material
Type	Brazing
Prescribed Specification in WWR	BS EN ISO 17672:2010 Brazing. Filler metals
Test item(s)	<ul style="list-style-type: none"> • Chemical composition

Category	Soldering material
Type	Soft solder alloy
Prescribed Specification in WWR	BS EN ISO 9453:2014 Soft solder alloys – Chemical compositions and forms
Test item(s)	<ul style="list-style-type: none"> • Chemical composition

Note:-

- 1) For chemical composition test, the grade of material shall comply with BS EN 1982:2008, BS EN 12420:2014, BS EN 12163:2016, BS EN 12164:2016, BS EN 12165:2016, BS EN 12167:2016, BS EN 10088-1:2014, BS EN 10088-2:2014, BS EN 10088-3: 2014, BS EN 10283:2010 or updated version except those material grades specified by the prescribed specification in WWR.
- 2) For non-metallic material in contact with fresh water intended for human consumption, the materials shall comply with the relevant requirements in BS 6920:2014.
- 3) Apart from the prescribed components in the summary above, chemical composition test shall be applied to metallic material in contact with water for a particular product where applicable.

Appendix 1A – Essential Aspects of Plumbing Design in New Buildings

(For reference only.)

Section A – Connection

Essential items:
1. Provide site location plan in scale 1:1000
2. Provide connection layout plan with the following details:
(a) Show the lot boundary line clearly
(b) Show the location(s) of connection pipe(s)
(c) Show the size(s) of connection pipe(s) and size(s) to be justified by estimated consumption
(d) Show the type of connection (single/dual/twin)
(e) [For FS]: provide independent connection for FS
(f) [For FS]: provide appropriate type of connection (single/dual feed)
<p style="text-align: center;">Example: Connection details (Fresh and Flushing Water Supply)</p>
<p style="text-align: center;">Example: Connection details (Fire Service Supply)</p>

Section B – Master Meter (MM), sub-meters (SM), check meters (CM) details

Essential items:

1. [FW, TMF, FS]: Development more than 1 building block

Yes → Go to Item 2A, 2B

No → Go to Item 2C

2A. General Arrangement of MM and CM:

- Conform to Fig. 1

2B. General Arrangement of SM at branch mains

- [FW, FS]: Conform to Fig. 1

2C. Government premises

Yes → General Arrangement details conform to Fig. 3 (application to all new government premises with Form WWO 542 received by WSD on or after 1st January 2021. Otherwise, refer to Fig. 2)

No → General Arrangement details conform to Fig. 2

Otherwise MM is required, go to Item 2A.

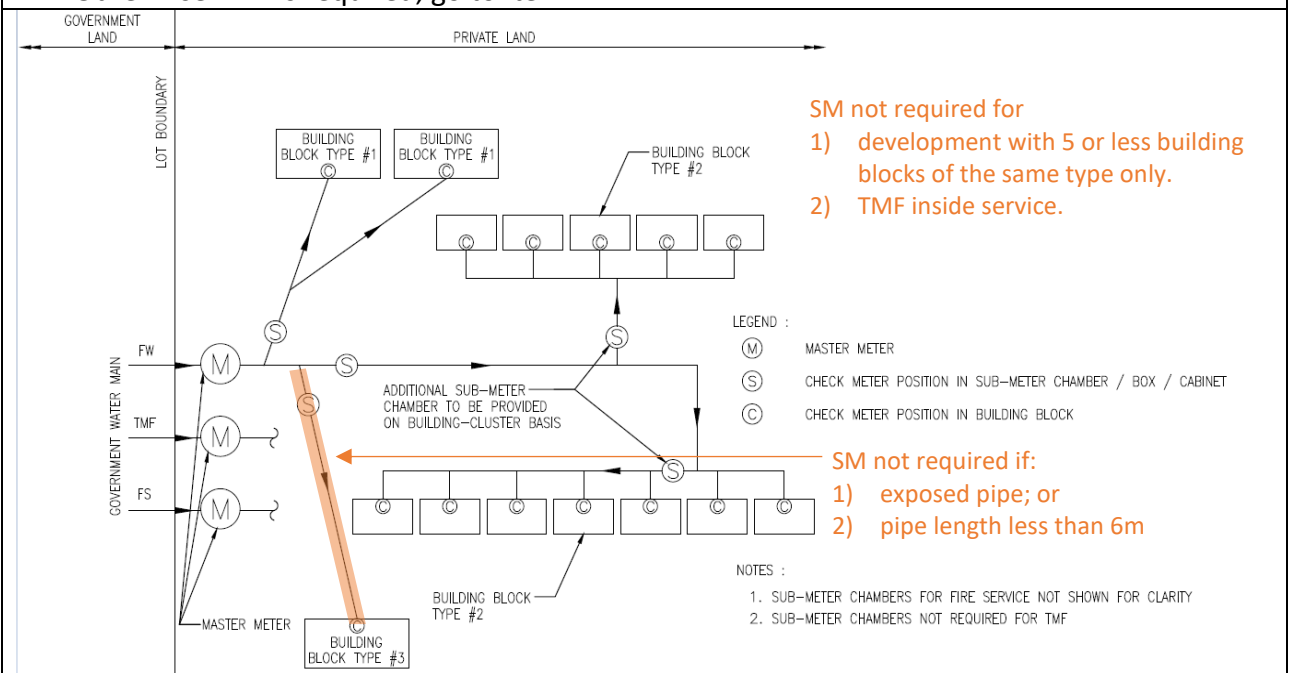

Fig. 1 Typical configuration of Master meter and Sub-meter chambers in Multiple-Block Development

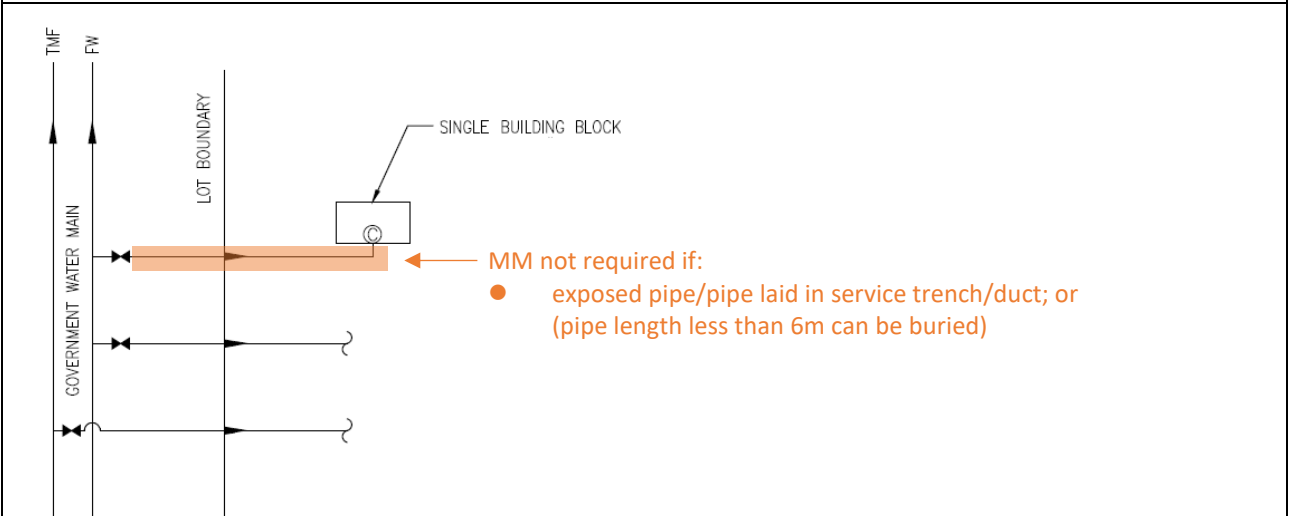

Fig. 2 Typical configuration of Master meter and Sub-meter chambers in Single-Block Development

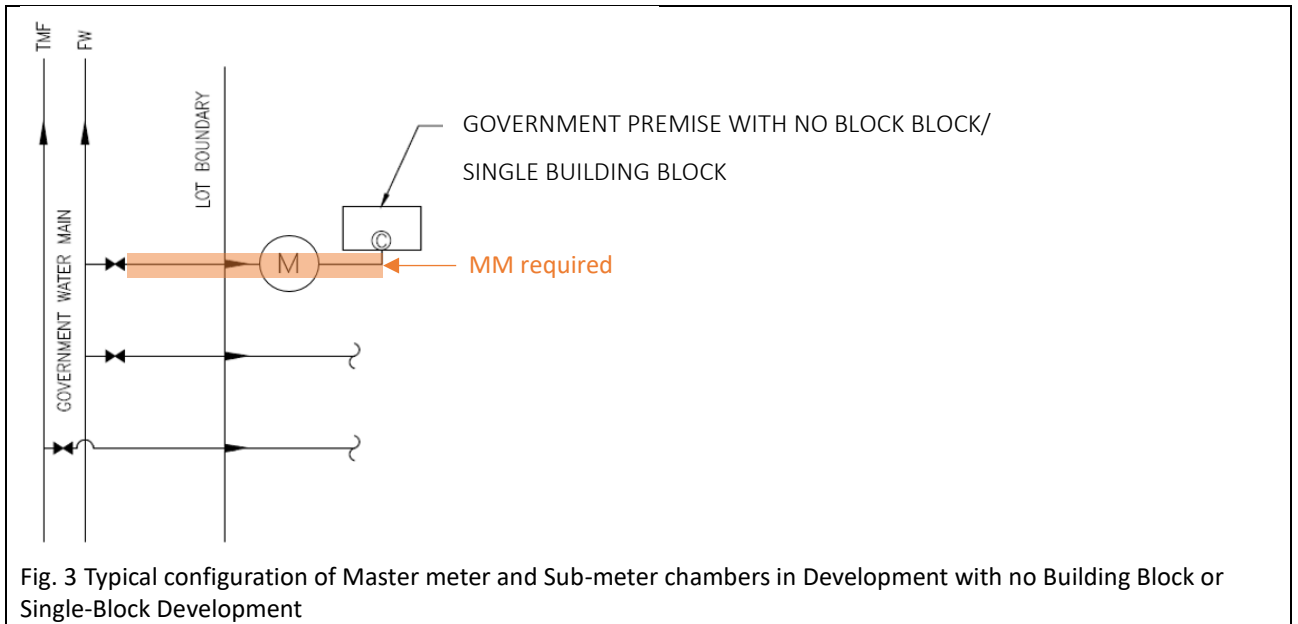

Fig. 3 Typical configuration of Master meter and Sub-meter chambers in Development with no Building Block or Single-Block Development

Section B – Master Meter (MM), sub-meters (SM), check meters (CM) details

3A. [MM]: Pipe diameter ≤ 100mm

- master meter box/cabinet, details conforms to Fig. 3.

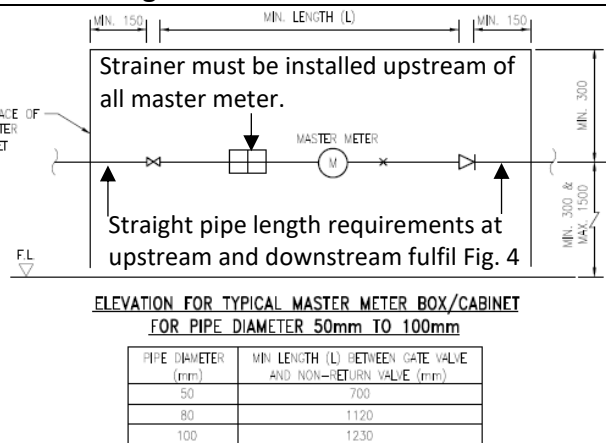
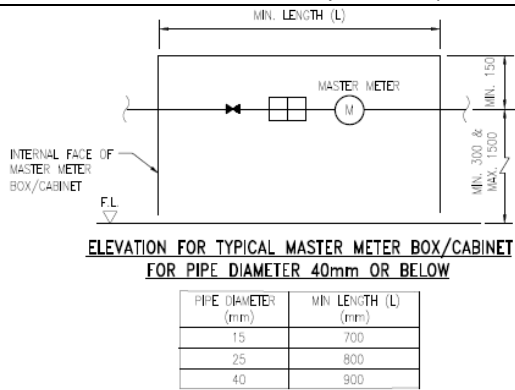
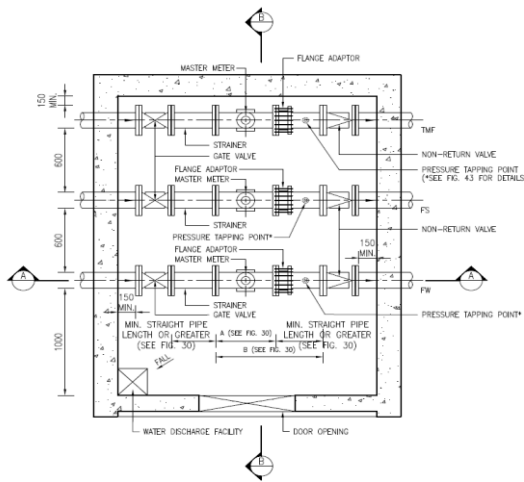

Fig. 3 Details of Master Meter Box/cabinet

3B. [MM]: Pipe diameter > 100mm

- master meter room, details conforms to Fig. 4.



MASTER METER OF VARIOUS SIZES

METER TYPE	SIZE (mm)	DIMENSIONS (mm)		STRAIGHT PIPE LENGTH REQUIREMENT	
		A	B (Minimum)	UPSTREAM	DOWNSTREAM
SINGLE JET	50	300	450	50	20
	80	350	720		
	100	350	730		
ULTRASONIC	50	200	450	30	20
TURBINE / WOLTMANN	50	310	450	50	20
	80	413	720		
	100	483	730		
	150	500	900		
	200	520	980		
	250	450	900		
ELECTROMAGNETIC	300	500	1000	30	20
	50	200	450		
	80	200	720		
	100	250	730		
	150	300	1000		
	200	350	1000		
250	400	1000			
300	500	1000			

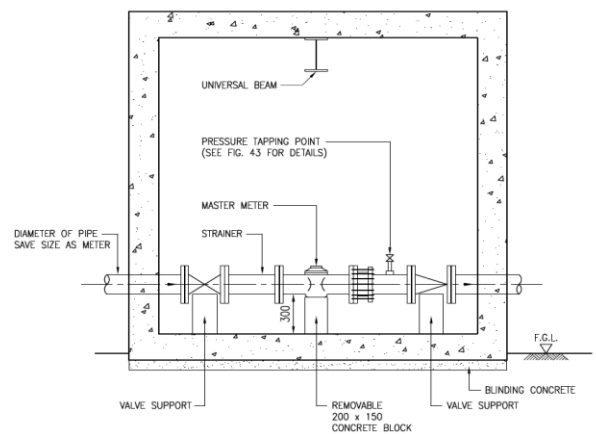
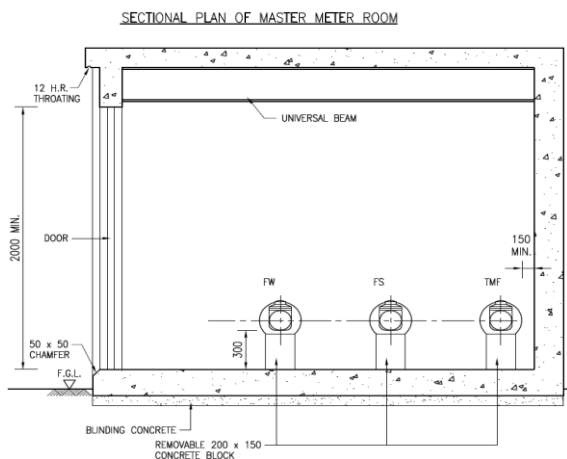

SECTION B – B OF MASTER METER ROOM

SECTION A – A OF MASTER METER ROOM

Fig. 4 Typical details of master meter room

Section B – Master Meter (MM), sub-meters (SM), check meters (CM) details

4. [MM]: Master meter room architectural requirements conform to Fig. 5.

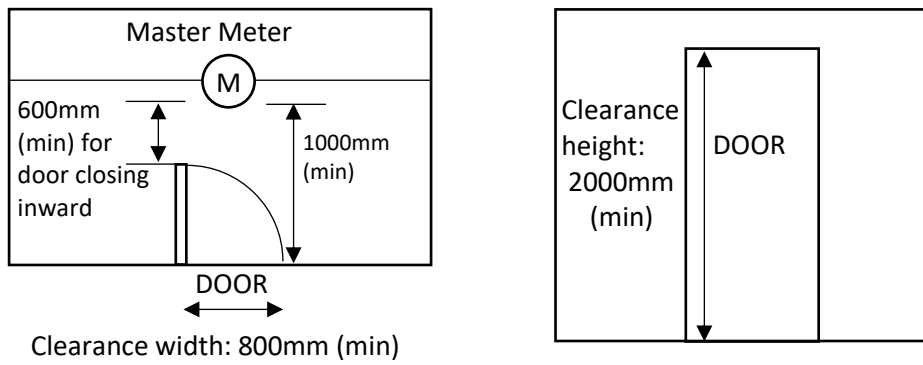

Fig. 5 Typical plan view and elevation view of master meter room

5. [SM]: Sub-meter chambers conform to Fig. 6.

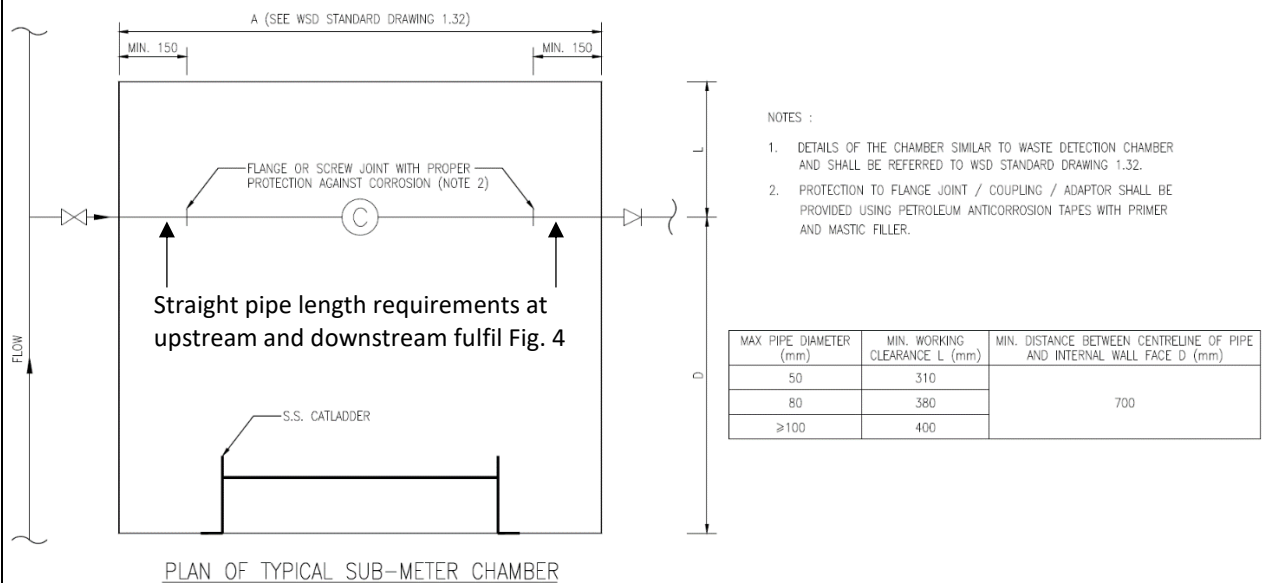

Fig. 6 Details of sub-meter chamber

6. [SM]: Sub-meter box/cabinet conform to Fig. 7.

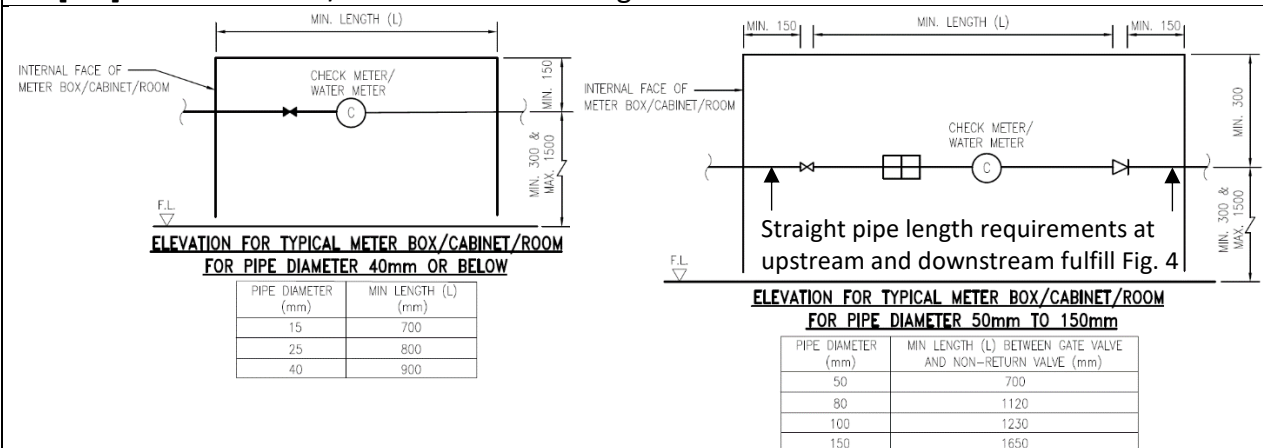

Fig. 7 Details of Check-meter/Water Meter Box/cabinet

Section B – Master Meter (MM), sub-meters (SM), check meters (CM) details

7. water meter position details conform to Fig. 8.

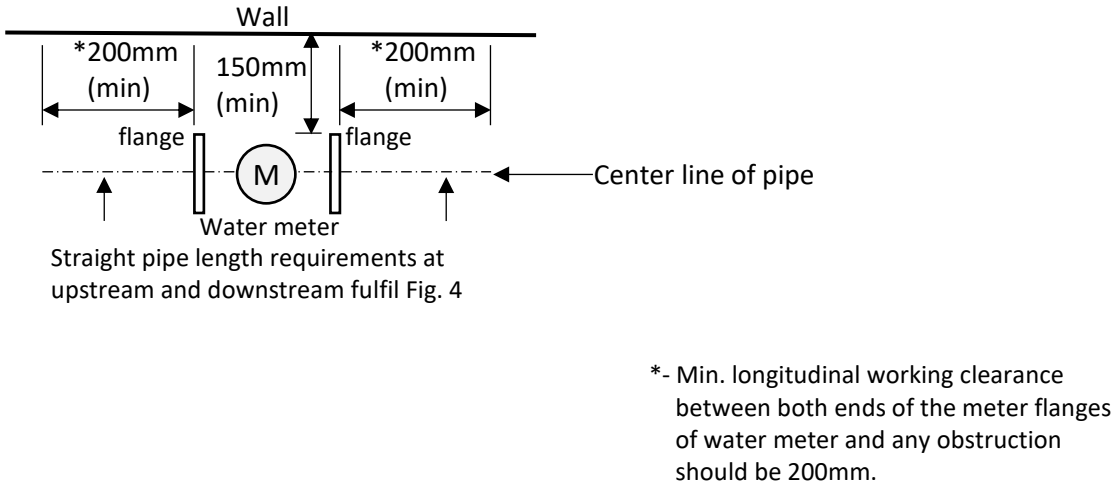

Fig. 8 Typical plan view of water meter position

Section C – Water storage tank details

Essential items:

1. Storage volume/size of storage required justified with design criteria below:

[FW] Storage Criteria:

- Domestic (sump and pump system)

Up to 10 flats	135 litres/flat (total storage including sump tank), minimum 500 litres
More than 10 flats	90 litres for each additional flat

- Trade/Commercial premises:

Food Shop	(Small)	900 litres	Not including provision of stores, fruiterers, etc.
	(Large)	1800 litres	
Restaurants		25 litres/seat (0.929m ² /person on net area) (1.394m ² /person on gross area)	
Barber's Shop and Beauty Parlour		135 litres/chair	
Funeral Parlour		45 litres/92.903m ² on gross area	
School	Drinking	4.5 litres/head	
	Laboratory	45 litres/sink	
Industry		100% of daily demand	
Clinic		250 litres (surgery only)	
Dentist		250 litres/dental unit	
Clubs	Kitchen	2.5 litres/member	
	Changing Rooms	90 litres/shower (hot and cold combined)	
Office Blocks		45 litres/point	
Cinemas/Theatres		45 litres/point	
Hotels	Bedrooms	45 litres/single room (hot and cold combined)	
		70 litres/double room (hot and cold combined)	
	Pantries, Bars and Laundries	Individual consideration	
Boarding Houses and Staff Quarters		25 litres/bed (hot and cold combined)	
Fire Stations, Police Quarters, Army Barracks		45 litres/person x 50% of establishment (ablution rooms only – hot and cold combined)	

- Laundry:

$$\text{Laundry Allowable Storage} = \frac{L}{T} \times 120 \text{ min.} \times N$$

where L = Litres/complete operational cycle
T = Time/complete operational cycle
N = No. of machines

- Hospital: the required storage criterion is one day's consumption as given by hospital authorities
- Industrial use: one-day demand
- Boilers: The required storage criterion is given in the following formula:

$$\text{Allowable Storage (litres)} = (\text{Boiler capacity (kW)} \times 15 - \text{percentage of water return (\%)}) \times \text{working hours.}$$

[FLW] Storage cistern capacity fulfilled the requirements below:

Building Types	Litres per flushing apparatus	Minimum capacity
Residential (Water closet)	30	250 litres
Commercial		
<ul style="list-style-type: none"> ● Urinal ● Water closet 	30 40	

Section C – Water storage tank details

2. Storage volume does not exceed maximum permitted capacity.
3. Storage volume exceeds 5,000 litres:
 - Yes → twin-tank system is required. (subject to availability of plant room space and for potable and flushing water tank)
 - No → either single or twin-tank is acceptable.
4. General arrangement of water cistern conforms to Fig. 9 below:
 - (a) Inlet, outlet pipe and drain-off pipe for each compartment
 - (b) Overflow pipe one commercial size > inlet pipe and extended to conspicuous position (or with overflow alarm with signal transferred to 24-hr manned management office)
 - (c) Warning pipe below overflow pipe and extended to conspicuous location (or with signal transferred to 24-hr manned management office)
 - (d) Stop valve, ball float valve and automatic control switch at inlet
 - (e) Physical break between potable and non-potable cistern
 - (f) **[FS]**: separate supply tank for fire service sprinkler/drencher system and any other FS (e.g. hose reel)

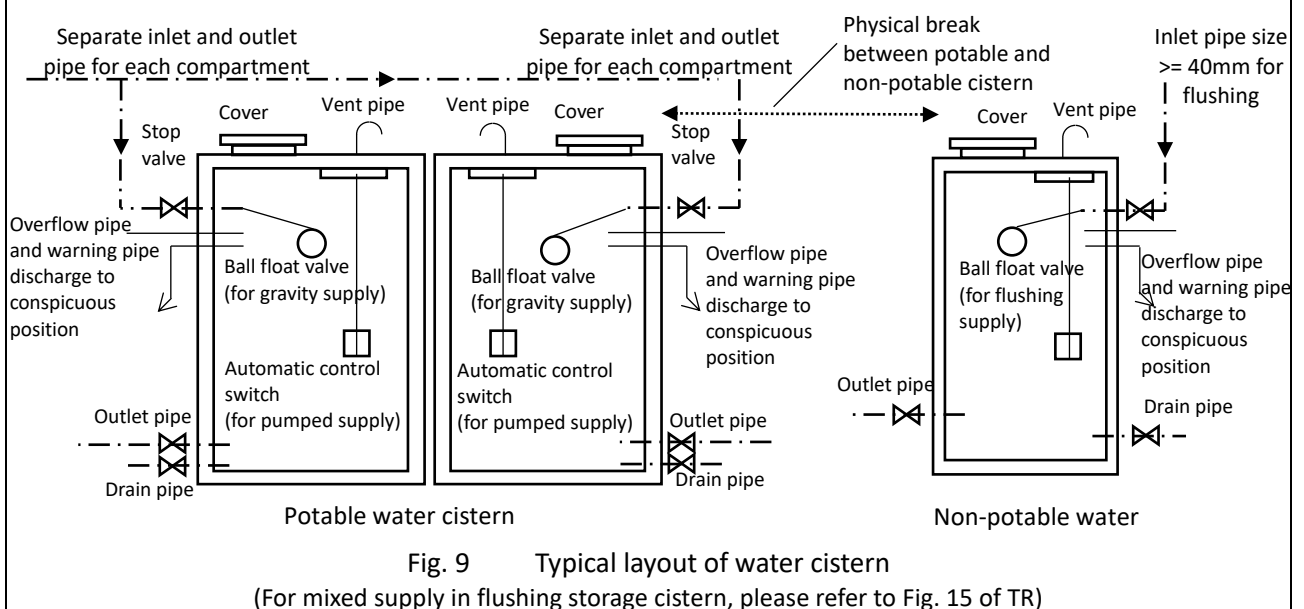

Section D – Water meter details

Essential items:

1. Water meters (other than master meter, sub-meters and check meters)

(a) Concessionary supplies must be separately metered.

(b) Meter room/box/cabinet/chamber details conform to Fig. 10.

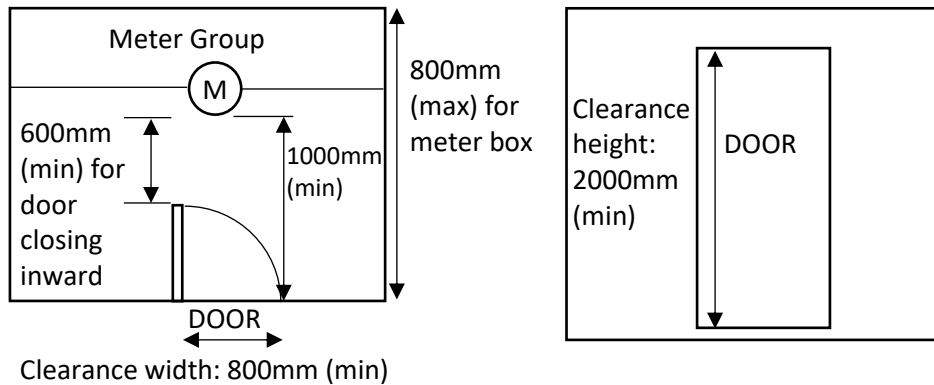

Fig. 10 Typical plan view and elevation of meter room/box

(c) Meter position (dimension and arrangement) inside meter room/box/cabinet conform to Fig. 11.

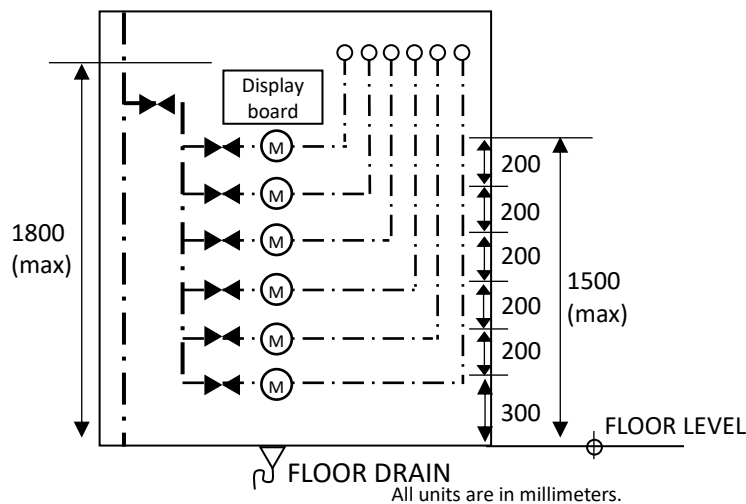

Fig. 11 Typical layout of 15mm meter position in a meter room/box/cabinet

(d) Minimum clearance should be provided for meters of trade supply according to Fig. 11a

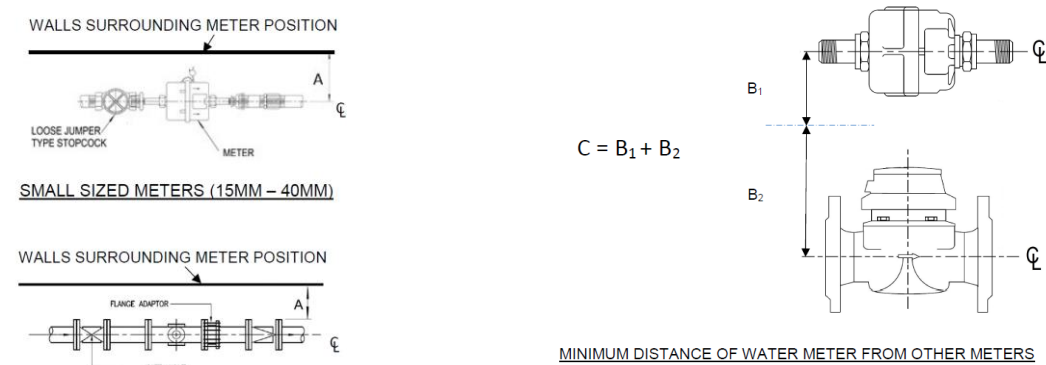

Fig. 11a

Nominal Size of water meters (mm)	Min. Distance of water meter and the surrounding wall (mm) [A]	Min. Distance of a meter from other meters (mm) [C]	Corresponding Dimension [B1 or B2]
15	100	B ₁ +B ₂ (B ₁ & B ₂ represent the corresponding dimension of the meters, see Fig. 36-3)	100
25	100		100
40	125		125
50	150 (Measure from flange edge of water meter to surrounding wall, see Fig. 36-2)	B ₁ +B ₂ or 400mm whichever is less	250
80-100		B ₁ +B ₂ or 500mm whichever is less	300
150		B ₁ +B ₂ or 600mm whichever is less	320
200		B ₁ +B ₂ or 600mm whichever is less	350
250		B ₁ +B ₂ or 600mm whichever is less	370
300		B ₁ +B ₂ or 600mm whichever is less	400

Section E – Other Miscellaneous details

1. [FW]: Water using appliances and other water application

- Prevention of backflow device(s) to be provided in the following applications:

Application	Backflow prevention devices
<ul style="list-style-type: none"> ● Irrigation (outlet >150mm above soil level, no fertilizer or insecticides, manual point supply) ● General ablution (basin, showers) ● Fire services 	<ul style="list-style-type: none"> ● Check-valve/non-return valve ● double check valve ● anti-vaccum vavle
<ul style="list-style-type: none"> ● Irrigation (outlet <150mm above soil level, no fertilizer or insecticides, drip-feed pipes) ● Kitchen with submerged inlet ● Commercial lanudries ● Industrial processes 	<ul style="list-style-type: none"> ● Break tank ● Backflow preventer/Reduced Pressure Zone Device

2. [FW]: Concessionary usages and supplies:

- Off-tank supply to be provided (including automatic irrigation system)
- Requirements for mains supply to be fulfilled (for irrigation uses by point supply, nurseries, sports field and planter at footbridges ,flyovers and roadways)

3. [FLW/TMF]: Flushing apparatus:

(a) Flushing cistern supplied by flushing storage tank

(b) Trough water-closet or urinal fitted with flushing storage tank

(c) water-closet fitment or slop sink fitted with flushing storage tank or pressure flushing valve

4. [FS]: Hydrant / fire hose reel must be supply off-tank.

5. [Cooling tower]: Must have joined the “Fresh Water Cooling Towers Scheme”.

[Non-centralized HW]:

1. Factory test pressure of heater ≥ 1.5 times maximum static pressure at mains water supply point:

Y → heater supplied without providing storage

N → heater supplied from cold water cistern of 45 litres for each flat

2. Roof storage cistern of indirect system:

- separate down feed supplying to the apparatus; or
- supplied through an oversized down feed pipe, the pipe supplying the hot water apparatus branched from the down feed at a point above the top of the apparatus

3. Layout of unvented electric thermal storage heater conform to Fig. 12.

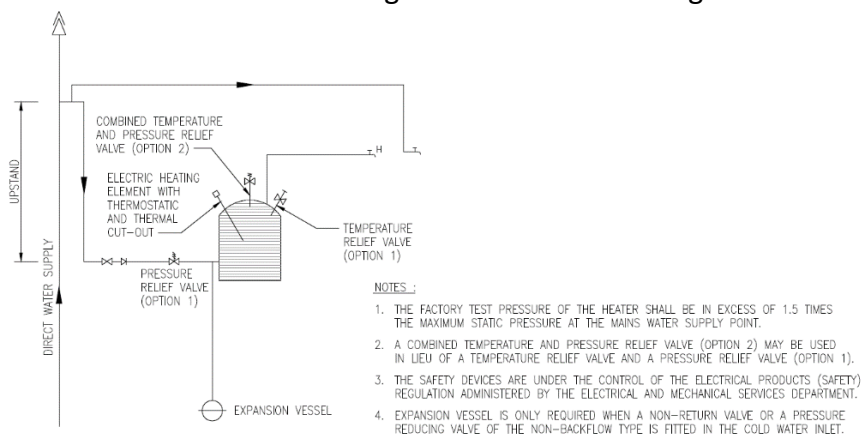
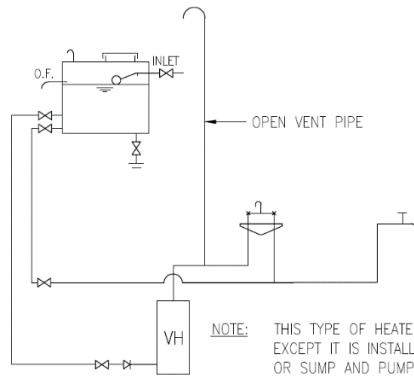

Fig. 12 Typical layout of unvented electric thermal storage type water heater

Section E – Other Miscellaneous details

4. Layout of pressure type thermal storage heater conform to Fig. 13.



Storage cistern of 45 litres for each flat for direct supply system.

Fig. 13 Typical layout of pressure type thermal storage type water heater

5. Gas Geysers installed on top floor through storage cistern:

- low pressure governors required when head available < 5m at the highest hot water draw-off point

6. Cold water supply to mixing valves, water blenders or combination fittings:

- drawn by same source as is supplying the hot water apparatus

[Centralized HW]

7. Layout conform to Fig. 14.

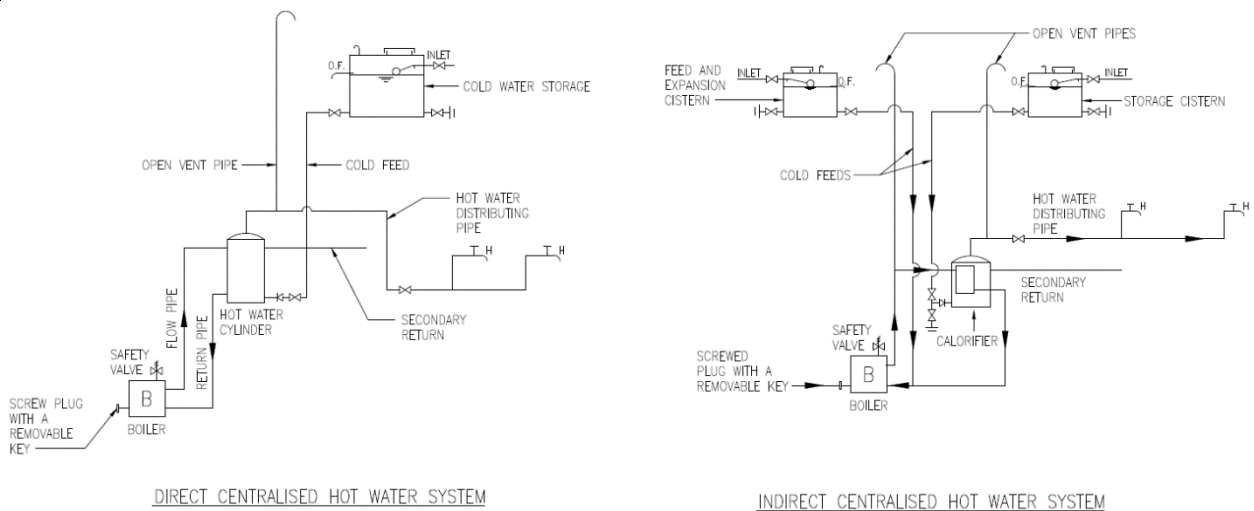
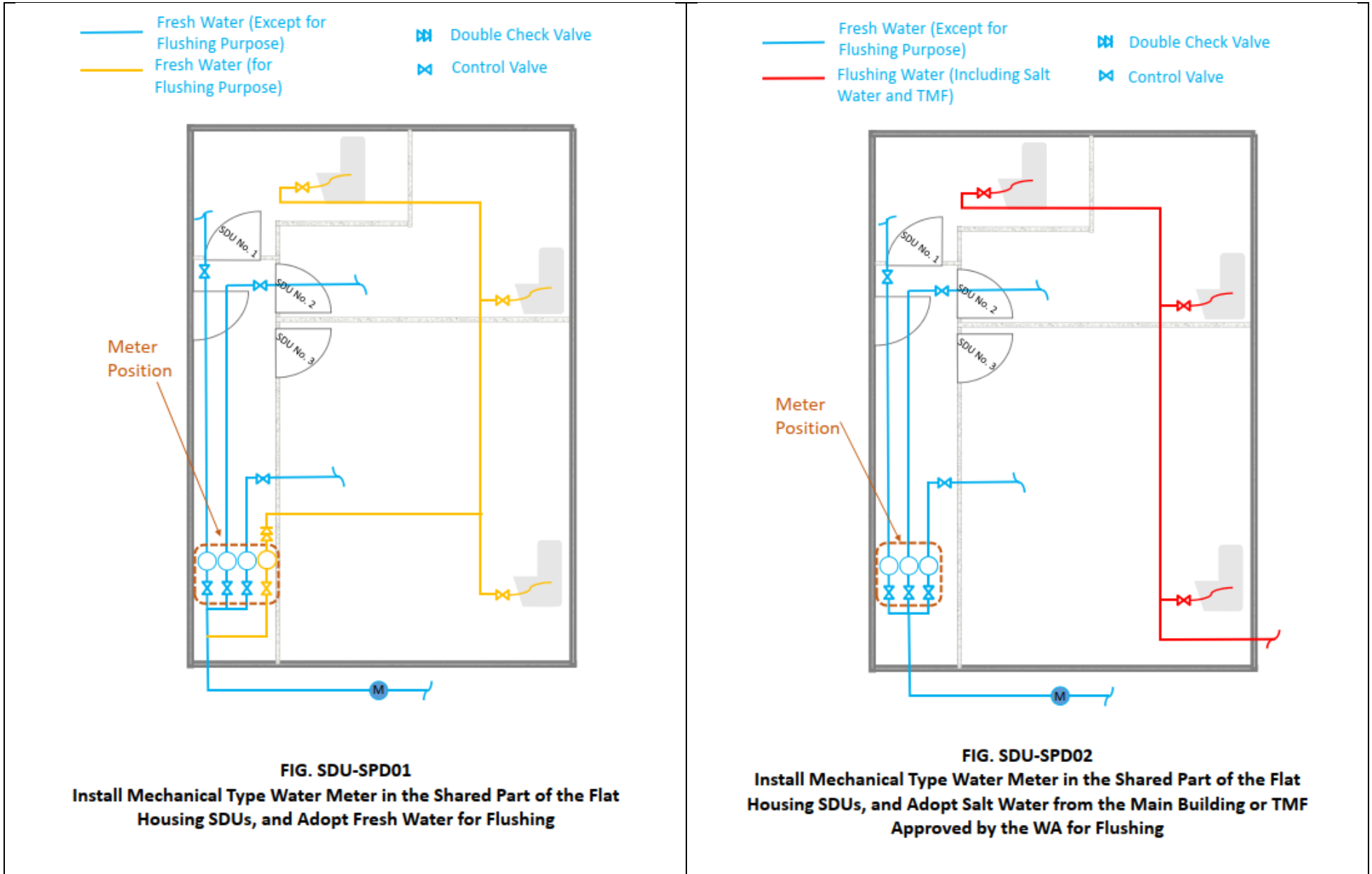

Fig. 14 Typical layout of centralized hot water system

8. Cold water supply to mixing valves, water blenders or combination fittings:

- drawn by a separate down feed from the hot water storage cistern
- outlet from storage tank shall be slightly lower than the feed to the hot water system

Appendix 2 – Standard plumbing drawings for subdivided unit (SDU)



Appendix 2 – Standard plumbing drawings for subdivided unit (SDU)

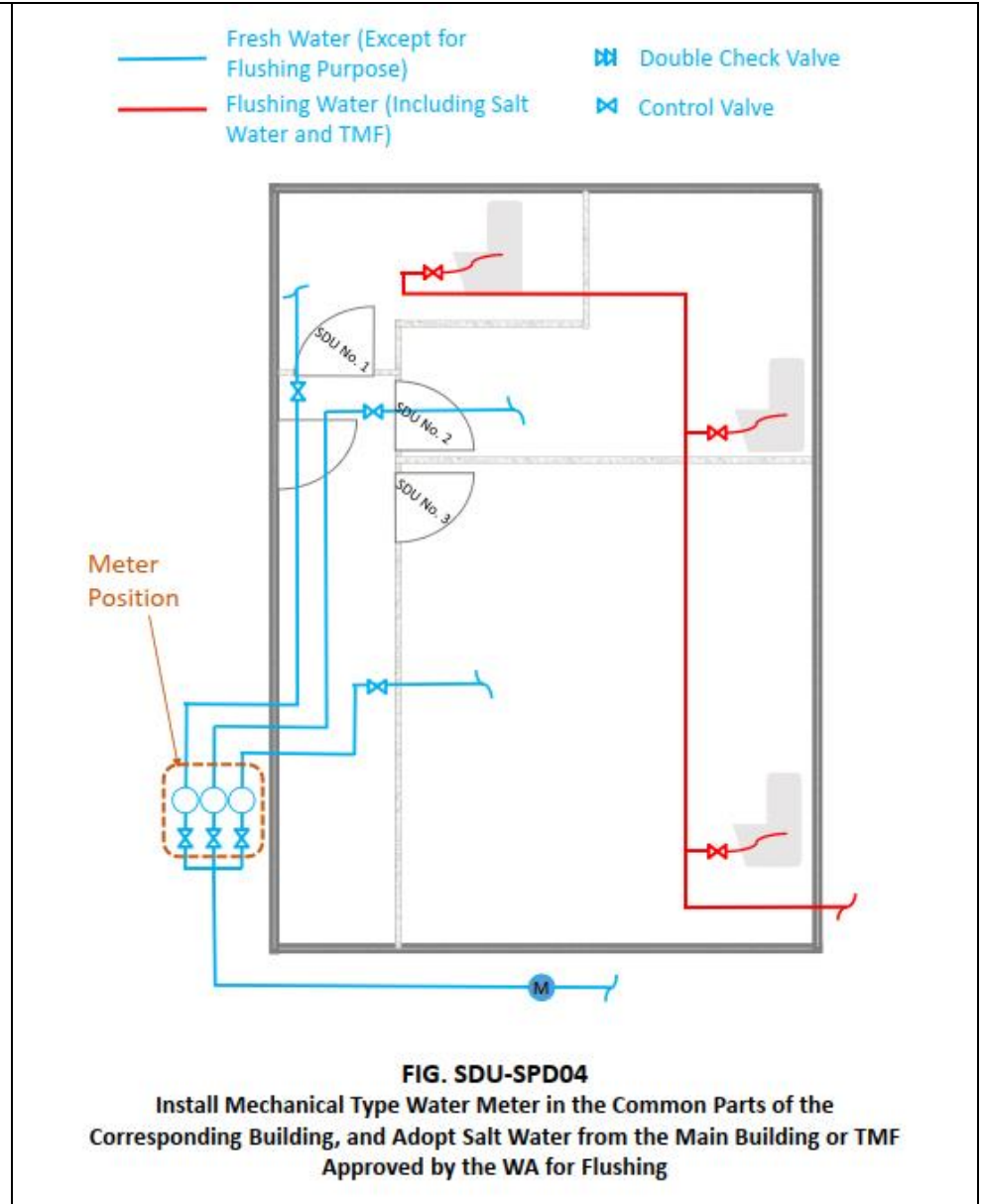
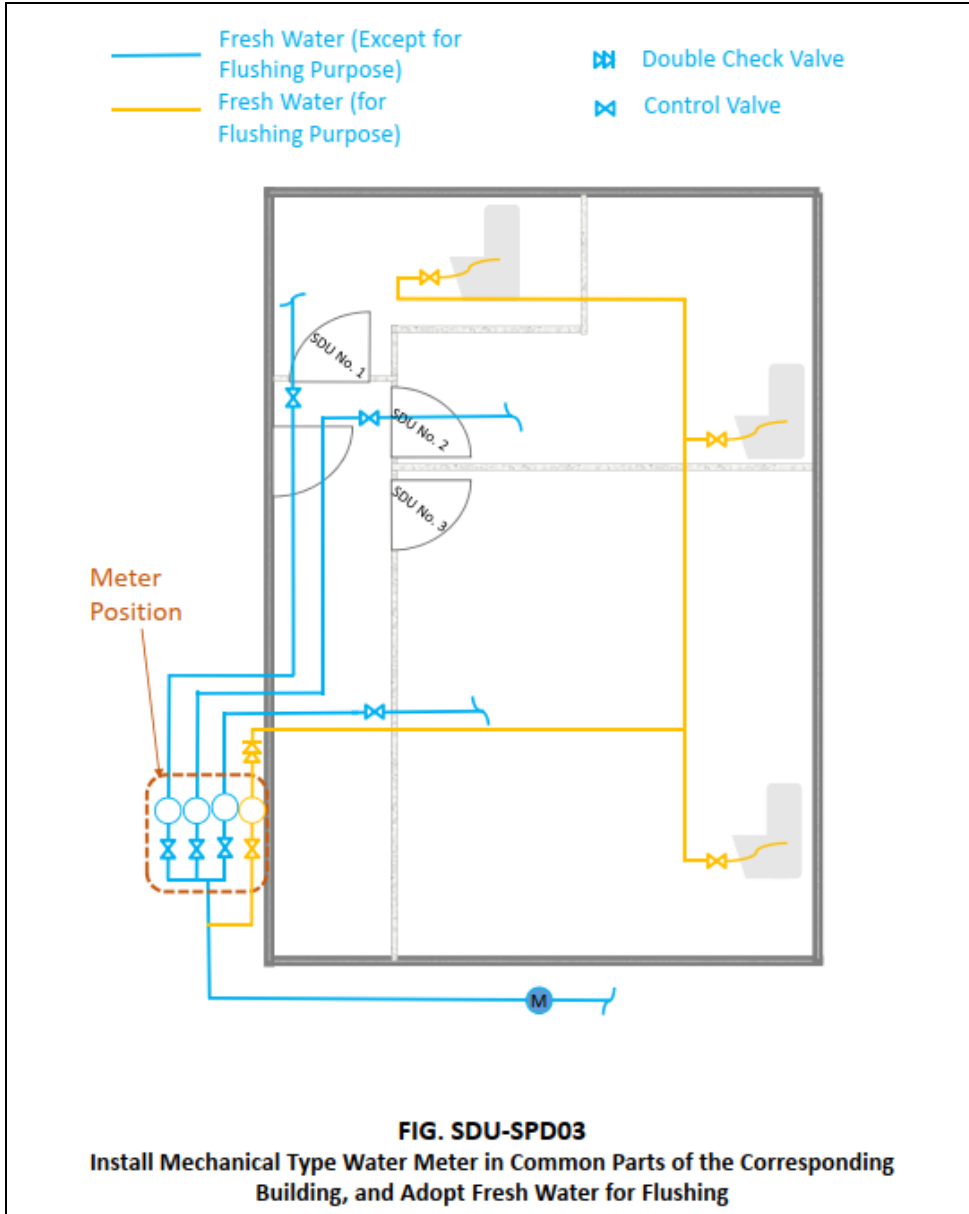

Appendix 2 – Standard plumbing drawings for subdivided unit (SDU)

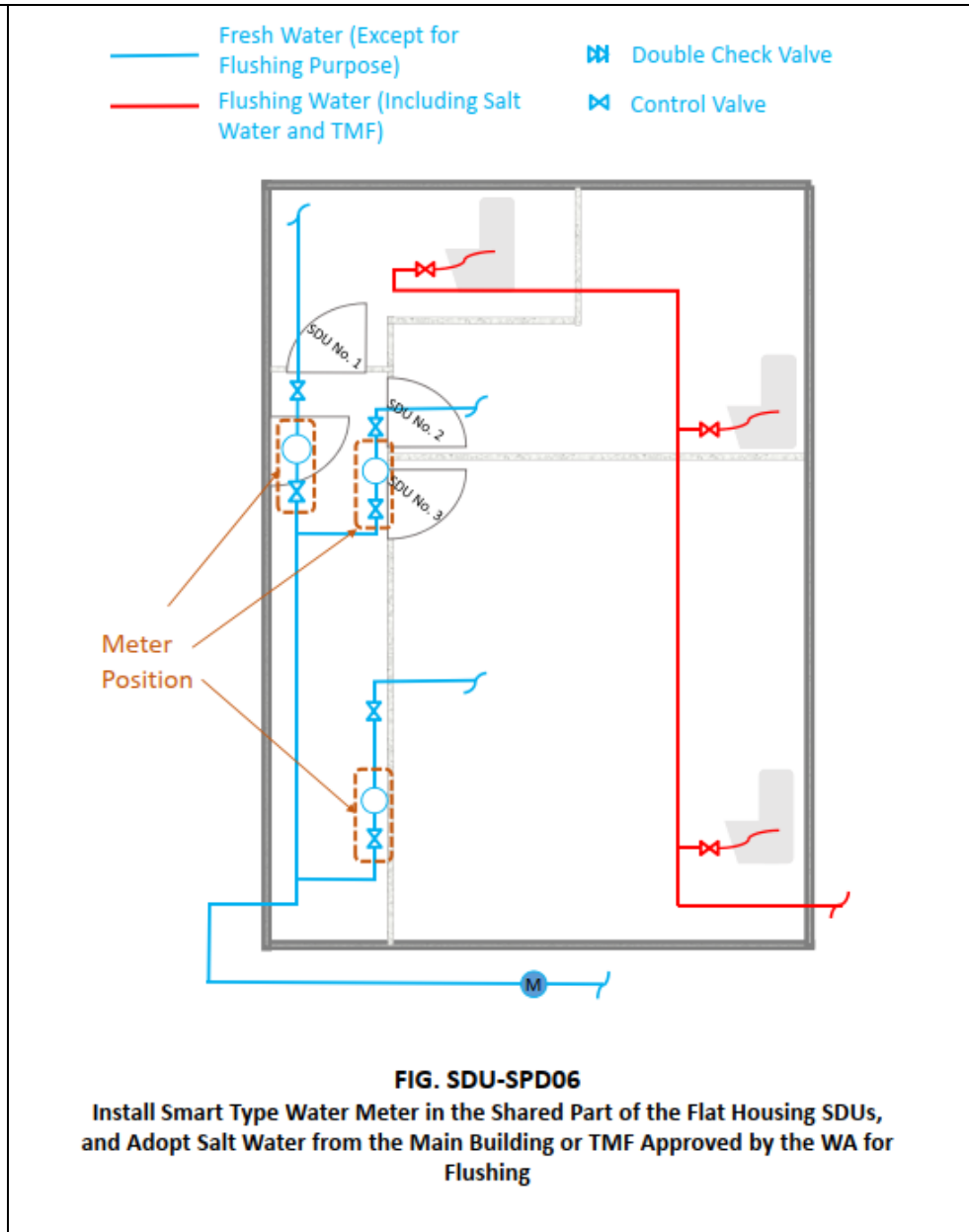
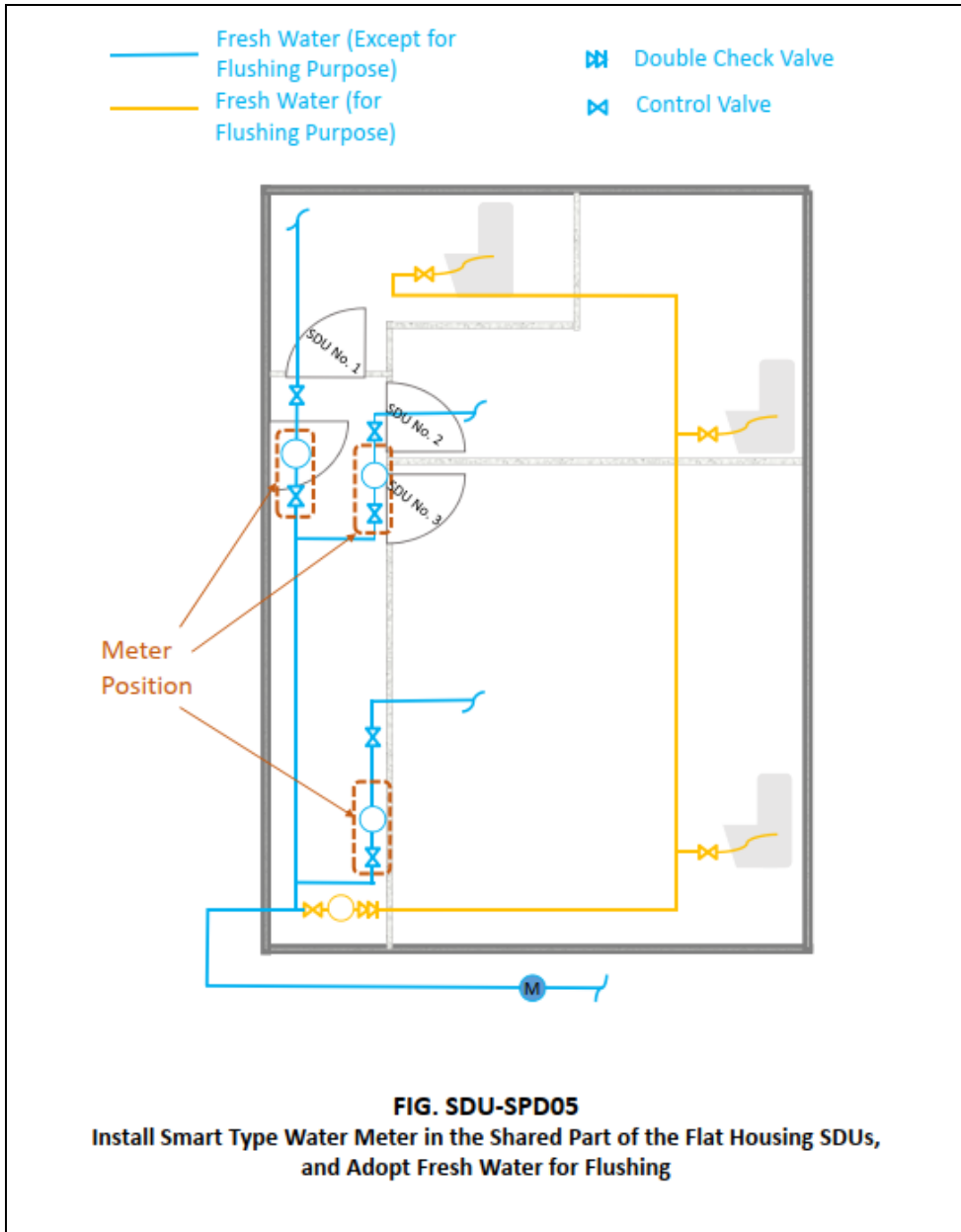

-END-