

Cad Ref. : WSD070301-H.dwg

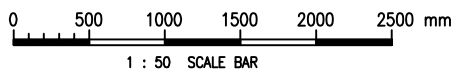

H	GENERAL REVISION	S.K. YEUNG	12/1/15
G	CAT-LADDER EXTENSION REVISED	S.K. YEUNG	8/8/13
F	NOTE 2 UPDATED	W.K. CHIU	18/7/08
E	RE-FORMATTED TO CSWP	W.K. CHIU	14/11/03
D	GENERAL REVISION & G.M.S. HANDGRIP DELETED	W.K. CHIU	20/9/00
C	GENERAL REVISION	K.W. CHAN	05/05/97
B	GENERAL REVISION	K.W. CHAN	28/08/96
A	GENERAL REVISION	K.W. CHAN	22/05/96
REF.	REVISION	APPROVED	DATE

VERTICAL LADDER —
INTERNAL ACCESS

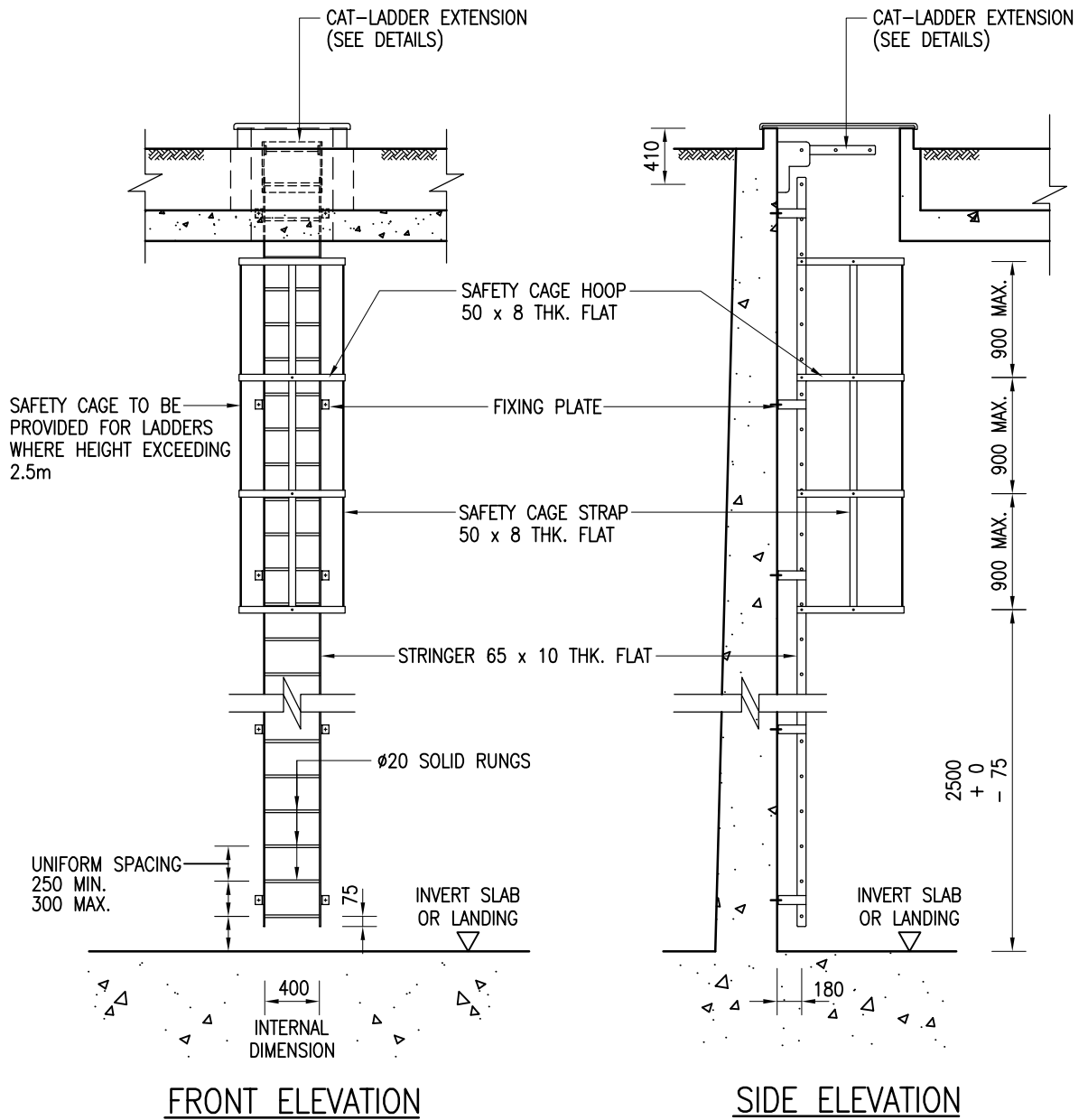

水務署
Water Supplies Department

APPROVED	G.C. LEE AD/NW	DRAWING NO.	CSWP
DATE	9/6/92	WSD 7.3H	(SHEET 1 OF 4)
SCALE	1 : 50		

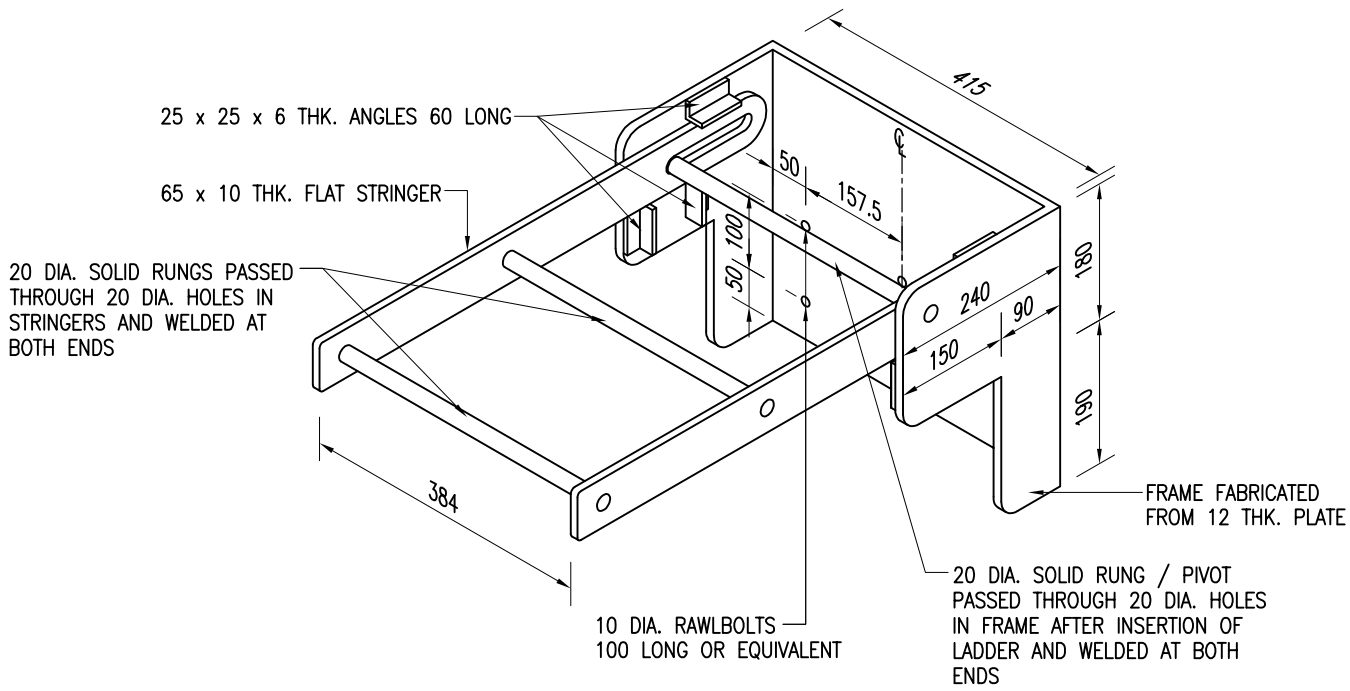

ISOMETRIC VIEW

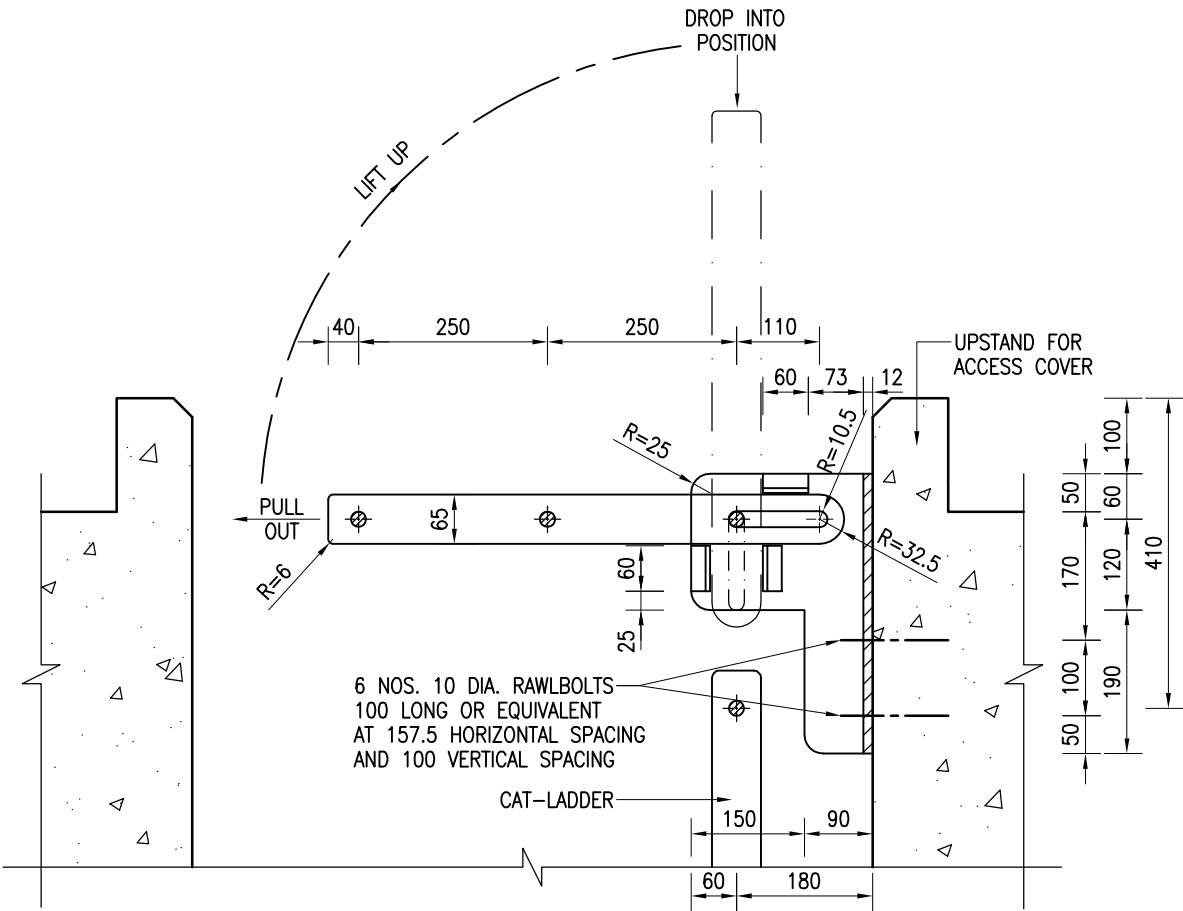

SECTION

CAT-LADDER EXTENSION

(APPLIES TO ALL 600 x 900 MANHOLE OPENINGS OR LARGER)

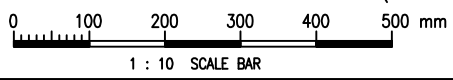

Cad Ref. : WSD070302-H.dwg

<p>VERTICAL LADDER — INTERNAL ACCESS</p>	 <p>水務署 Water Supplies Department</p>		<p>DRAWING NO. CSWP</p>
	<p>APPROVED</p>	<p>G.C. LEE AD/NW</p>	<p>WSD 7.3H (SHEET 2 OF 4)</p>
	<p>DATE</p>	<p>9/6/92</p>	
<p>SCALE</p>	<p>1 : 10</p>		

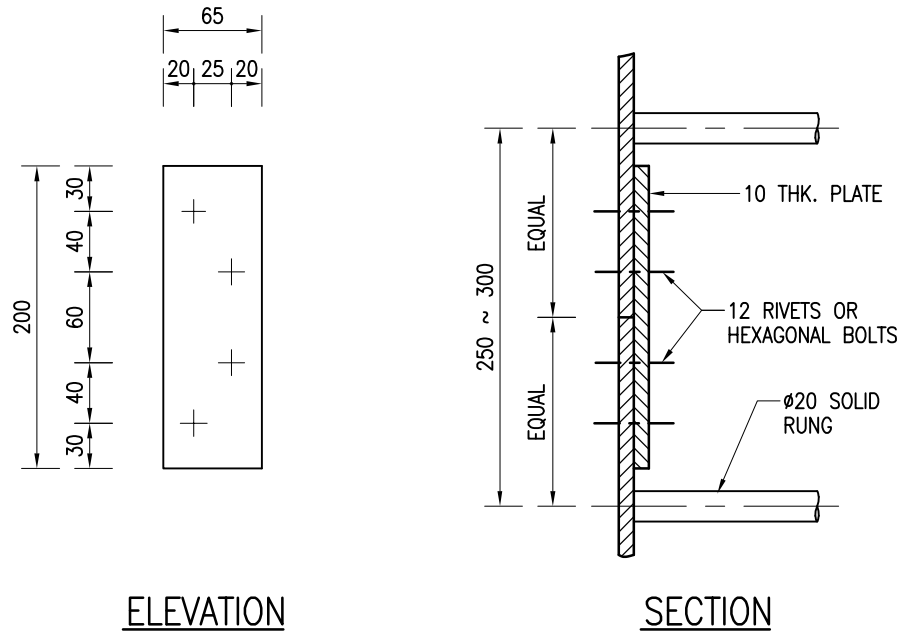
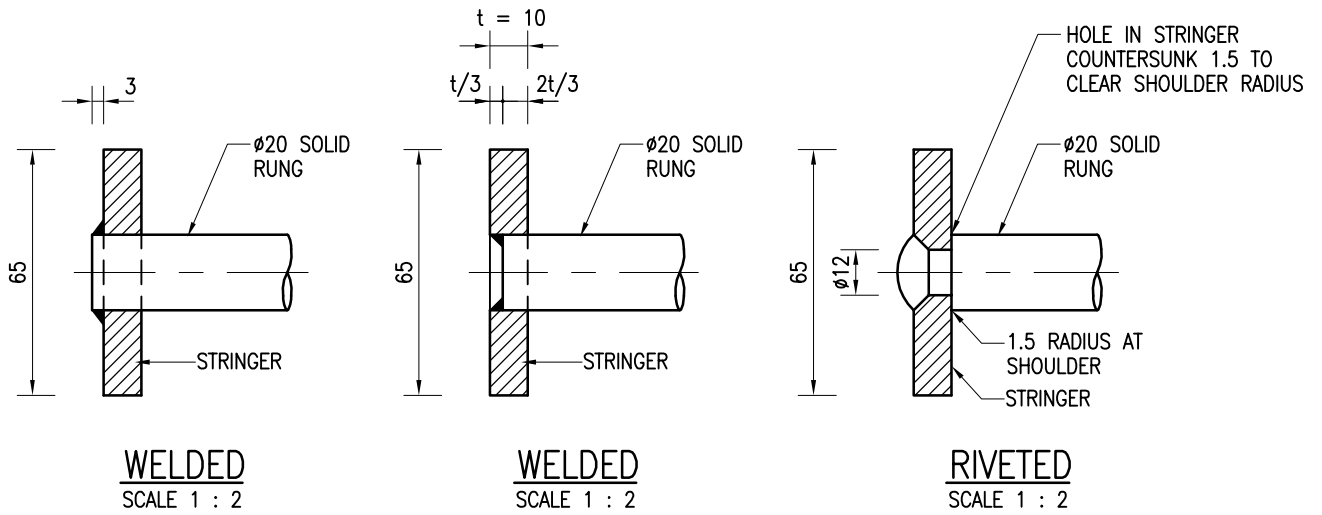

FISH PLATE

TYPICAL DETAILS OF CONNECTIONS

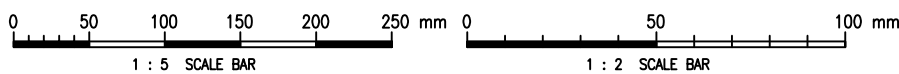

Cad Ref. : WSD070303-H.dwg

VERTICAL LADDER —
INTERNAL ACCESS



水務署
Water Supplies Department

APPROVED	G.C. LEE AD/NW	DRAWING NO.	CSWP
DATE	9/6/92	WSD 7.3H	(SHEET 3 OF 4)
SCALE	1 : 5 OR AS SHOWN		

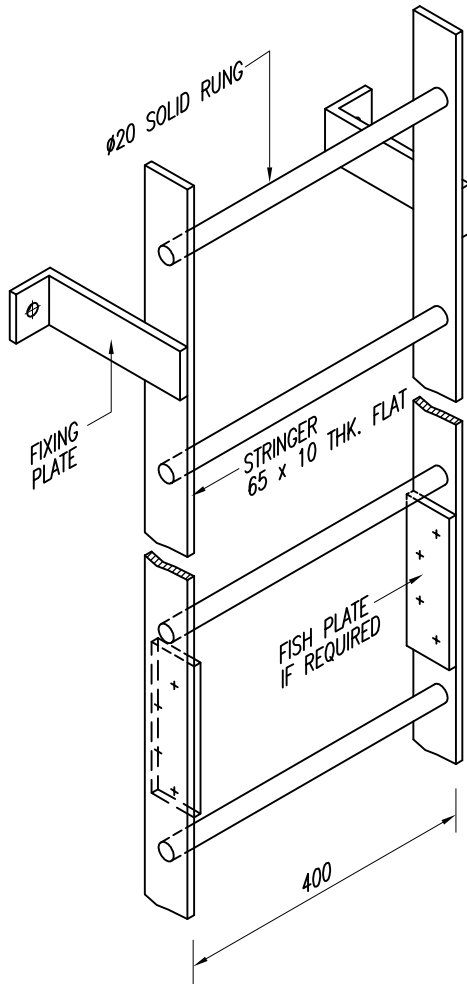

ISOMETRIC VIEW OF VERTICAL LADDER

N.T.S.

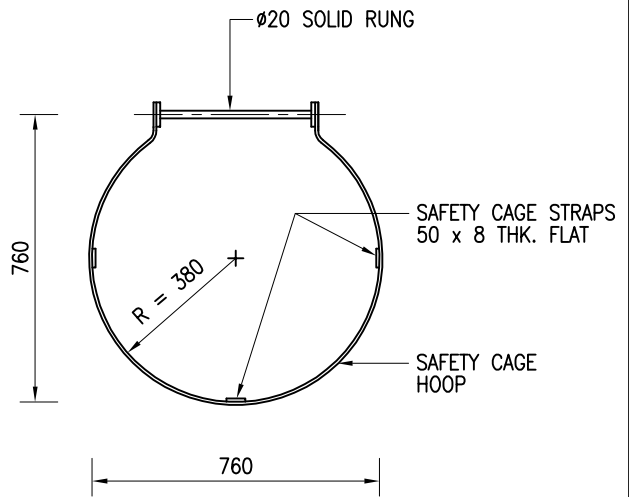

CIRCULAR HOOP

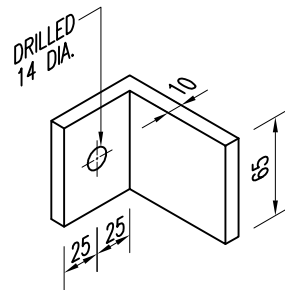

FIXING PLATE

SCALE 1 : 5

NOTES :

1. ALL DIMENSIONS ARE IN MILLIMETRES.
2. THE MATERIALS USED FOR THE CONSTRUCTION OF LADDERS, HOOPS AND CONNECTIONS SHALL BE EITHER STAINLESS STEEL OF STEEL NUMBER 1.4404 TO BS EN 10088-1 OR MILD STEEL HOT-DIP GALVANIZED TO BS EN ISO 1461, AS SPECIFIED IN THE CONTRACT.
3. FIXING PLATES WELDED TO STRINGERS SHALL BE PROVIDED AT INTERVALS NOT EXCEEDING 2m BETWEEN FLOOR HEIGHTS.
4. SAFETY CAGE SHALL BE PROVIDED WHERE HEIGHT OF LADDER EXCEEDS 2.5m.
5. FIXING SHALL BE BY 12mm SELF DRILLING ANCHOR.
6. HOLES IN STRINGER SHALL BE DRILLED TO GIVE 0.8mm CLEARANCE.
7. THREE VERTICAL SAFETY CAGE STRAPS SHALL BE FITTED INTERNALLY TO BRACE THE HOOPS IN THE POSITIONS SHOWN. WHERE BOLTED CONNECTION ARE USED, M12 BOLTS OF COUNTERSUNK OR CUPHEAD TYPE SHALL BE USED WITH THE HEAD ON THE INSIDE.
8. DETAILS OF R.C. STRUCTURES SHOWN ON THIS DRAWING ARE TYPICAL ONLY.

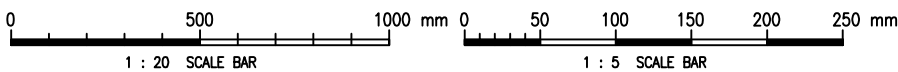

Cad Ref. : WSD070304-H.dwg

**VERTICAL LADDER —
INTERNAL ACCESS**



**水務署
Water Supplies Department**

APPROVED

G.C. LEE
AD/NW

DATE

9/6/92

SCALE

1 : 20 OR AS SHOWN

DRAWING NO.

WSD 7.3H

(SHEET 4 OF 4)

CSWP