

FOR PE PIPE NOMINAL SIZE 63 AND BELOW

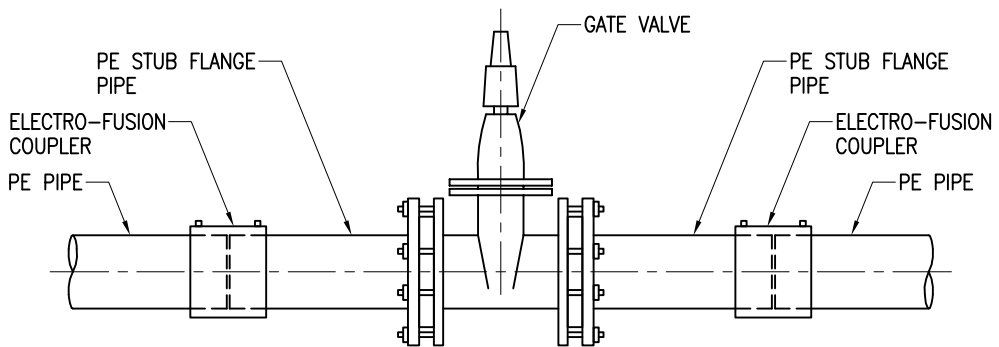

FOR PE PIPE NOMINAL SIZE 90 AND ABOVE

NOTES :

1. FOR INSTALLATION DETAILS OF GATE VALVE OF NOMINAL DIAMETER 80mm AND ABOVE, MECHANICAL JOINT USING AQUAGRIP FLANGE ADAPTOR OR EQUIVALENT CAN ALSO BE CONSIDERED.
2. THE METAL PART OF THE TRANSITION ADAPTER, WHEN USED IN A SALT WATER PIPELINE AND IN CONTACT WITH THE COPPER ALLOY CC491K GATE VALVE, SHALL BE CC491K OR OTHER APPROVED MATERIAL WHICH WILL NOT GIVE RISE TO GALVANIC CORROSION.

Cad Ref. : WSD014501-A.dwg

A	GENERAL REVISION	S.K. YEUNG	31/10/12
REF.	REVISION	APPROVED	DATE

TYPICAL INSTALLATION DETAILS
FOR GATE VALVES IN
POLYETHYLENE PIPES



水務署
Water Supplies Department

APPROVED	C.H. NG AD/NW	DRAWING NO. WSD 1.45A	CSWP
DATE	31/3/08		
SCALE	N.T.S.		