

Guidelines for Excavation near Water Mains

1. Introduction

- 1.1 All water mains are critically tested after installation and before being put into service. They should have a very long service life if they are not subsequently disturbed. However, main bursts do occur from time to time bringing about many undesirable consequences, such as water supply interruptions, inconvenience to the public, loss of productivity, disturbances to road traffic, damage and very expensive repair costs. It has been noted that most of the main bursts are caused by external factors, many of which are related to roadworks and road opening activities.
- 1.2 The permittee, or the nominated permittee, of an excavation permit has legal obligations to protect existing utility services, including water mains, from damage.
- 1.3 These guidelines are issued to help the permittee and/or nominated permittee (i.e. contractor) to prevent damage to water mains, but compliance with these guidelines will not relieve them of any of their legal and/or contractual obligations.

2. Pipe Materials

- 2.1 In Hong Kong, pipe materials commonly used for various sizes of existing water mains are as follows:

<u>Pipe Material</u>	<u>Nominal Diameter</u>
Steel (S)	100 mm and above
Ductile Iron (DI)	80 mm to 600 mm
Asbestos Cement (AC)	100 mm to 450 mm
UPVC	100 mm and below
Un-lined Galvanised Iron (GI)	150 mm and below
Lined Galvanised Iron (GIL)	150 mm and below
Polyethylene (PE)	250 mm and below
Stainless Steel (SS)	50 mm and below
Cast Iron (CI)	450 mm and below

Photos showing the above mentioned types of pipe materials are attached at [Appendix I](#) for reference.

2.2 Steel Pipes

- Strong in resisting impact and tensile stress, but relatively prone to corrosion.
- Normally used for large diameter pipes and for exposed pipes with long spans.

- 2.3 Ductile Iron Pipes
- Durable in withstanding internal and external pressure, but anchorage with concrete thrust blocks is required at bends and ends.
- 2.4 Asbestos Cement Pipes
- Durable in withstanding internal water pressure, but relatively more brittle and weaker than S and DI pipes in withstanding external load or pressure.
 - Use of AC pipes has been discontinued since January 1986, but there is still a considerable quantity of these pipes in the existing water supply systems. Statutory requirements shall be complied with for the safe handling, removal, transportation and disposal of AC pipes.
 - AC pipe bursts are often the result of being disturbed by trench works or ground movement in the vicinity and damaged by construction works.
- 2.5 UPVC Pipes
- Relatively weak in resisting direct impact.
 - Mostly used for small diameter salt water mains outside carriageways, but use of UPVC pipes has been discontinued for new works since December 2000.
- 2.6 Galvanised Iron Pipes
- Strong in resisting impact and tensile stress, but prone to corrosion.
 - Used only for small diameter fresh water mains and commonly in exposed manner, especially in rural areas.
 - GI pipes are no longer in use for new works since early 1995. GIL pipes have then been used instead as they are more resistant to internal corrosion.
- 2.7 Polyethylene Pipes (Blue or Black)
- Adopted for use in the fresh water supply system under buried condition since October 1998 and extended for general use in the salt water supply system under buried condition since December 2000 to phase out buried GI and UPVC pipes of DN 250 mm and below for both fresh and salt water supply systems.
 - Adopted for use in exposed salt water service connections (i.e. black PE pipes) in lieu of UPVC pipes since 2007.
 - Corrosion free and strong in withstanding internal and external pressure.
- 2.8 Stainless Steel Pipes
- Adopted for use in exposed fresh water service connections in lieu of small diameter GI pipes since 2007.
- 2.9 Cast Iron Pipes
- Use of CI pipes has been discontinued for many years, but some of these pipes still exist in the existing water supply systems.

3. Pipe Joints

- 3.1 Joints connecting AC, DI and S pipes with plain ends rely on a mechanism to grip the pipe body, with rubber rings to achieve water tightness. All these joints are not designed to take longitudinal stress and may be detached if the water main is not properly supported or anchored.
- 3.2 Longitudinal stress is commonly found at bends and closed ends of a pressurised pipeline. Concrete thrust blocks are normally cast at these locations to provide the necessary anchorage for withstanding the full thrust.

4. Common Causes of Main Bursts

- 4.1 Main bursts are caused by a variety of factors. Common external factors relating to road opening works are:
 - direct damage of water mains and valves by indiscriminate or reckless use of construction plant;
 - ground settlement or movement causing excessive angular distortion by excavation work;
 - disturbance of lateral or vertical support to water mains; and
 - excessive stress, vibration, movement or loading caused by piling, blasting, heavy mechanical plant or construction traffic.

5. Procedures & Practices for Safe Working near Water Mains

- 5.1 Most of the main bursts are caused directly or indirectly by road opening works. The works contractors should note the fact that there is an extensive network of water mains underneath the carriageways and footways. **It is essential that they should follow the procedures and practices (DOs & DON'Ts) described below for safe working near water mains** and exercise due care to avoid causing damage to the water mains in the execution of their works.
- 5.2 DOs - Taking Precautionary Measures
 - 5.2.1 Step 1: Circulate Layout Plans to WSD

Circulate layout plans with relevant details to Water Supplies Department (WSD) to request indication of the alignment of existing water mains in the vicinity, before commencing any excavation (see relevant conditions of excavation permit issued by Highways Department (HyD) or Lands Department).
 - 5.2.2 Step 2: Check Pipeline Alignment
 - Check the marked-up plans or mains record plans returned from WSD to note any existing water mains that may be affected, before starting any excavation.
 - Beware that the alignments of the water mains shown in the plan(s) are indicative only.

Moreover, although it is WSD's intention to provide the contractor with the most up-to-date information, it cannot be guaranteed that the information of all laid water mains, e.g. the recently laid mains, has been incorporated in the central records and hence shown in the returned plan(s). The contractor shall follow the procedures and practices described in the Guidelines and "How to Prevent Damage to Water Mains" posted on WSD Internet Homepage and take all necessary steps to prevent damage to the water mains or waterworks installations.

5.2.3 Step 3: Use of Pipe Detector

Make use of suitable pipe detector to ascertain as accurately as possible the alignments and depths of water mains near the work, before digging trial holes.

5.2.4 Step 4: Hand-dug Trial Holes

Dig trial holes by hand tools to ascertain the presence of any existing water mains, their exact positions and depths, before using mechanical plant for excavation, especially when water mains are identified in step 2 or detected in step 3.

5.2.5 Step 5: Consult WSD Staff

Contact the relevant Inspector/Region(Inspection) of WSD as listed in [Appendix II](#) for assistance, whenever there are uncertainties or problems with regard to the locations and protection of existing water mains. (A sketch showing the boundaries of the four WSD Regions is attached at [Appendix III](#)).

5.2.6 Step 6: Execute the Work Safely

Execute the work safely by strictly observing the following requirements:

- [Careful Operation of Heavy Mechanical Plant](#)

Be careful in operating heavy mechanical plant, especially in close proximity to existing water mains and valves. Excavation close to or around water mains should be carried out by hand digging method.

- [Protective Measures](#)

Implement all necessary protective measures to adequately support and protect the exposed water mains, including the associated thrust blocks and valves.

(A sketch suggesting how supports to water main should be provided is attached at [Appendix IV](#) for reference. The suggested method is by no means exhaustive and the details shall depend on site conditions and the type, size and length of the water main to be supported.)



- Adequate Site Supervision and Control

Provide adequate site supervision and control to ensure that all the above requirements are closely observed, and remind the workers from time to time of the importance of avoiding damage to water mains and the full consequences of the damage.

- Access

Make available free access at all times for WSD staff and their contractors to carry out inspection, operation, maintenance or repair works on the water mains.

- Clearance between services to be installed and existing water mains

Provide a clearance of not less than 300 mm between the services to be installed and the existing water mains for protection and for maintenance purposes. If such clearance cannot be provided, consult the relevant Inspector/Region(Inspection) of WSD as soon as possible.

5.2.7 Step 7: Backfilling of Pipe Trenches

Notify WSD staff to inspect the waterworks installations before backfilling the pipe trenches, and backfill with suitable materials in layers with adequate compaction to prevent ground settlement adjacent to or below existing water mains. (See paragraph 6 also)

5.3 DON'Ts - Avoiding Malpractices

Apart from taking those precautionary measures mentioned in paragraph 5.2, **the contractor should also avoid the following malpractices during excavation** to prevent damage to water mains:

- **DON'T pass heavy plants, such as excavator or compaction roller, over buried water mains after the road surfacing is removed** when the cover to the water mains is much reduced. This is to prevent possible pipe damage due to excessive loading.
- **DON'T disturb or expose any thrust block without WSD's prior agreement.** Exposure of a thrust block without providing proper support may result in its movement and detachment of the associated pipe joints and eventually a burst. WSD should therefore be consulted on all cases where exposure of thrust blocks or water mains are required to enable suitable protective measures to be taken.
- **DON'T just use steel wire ropes or chain blocks to support the exposed water mains.** I-beams/R.S.J. should be used to provide proper vertical and lateral support as suggested in the sketch at Appendix IV.
- **DON'T undermine water mains when excavating trench alongside or across it.** This is to prevent settlement of ground adjacent to or below existing water mains.

- **DON'T stockpile excavated materials within 1.5 m around valve covers or hydrants.** This is to ensure that the valves and hydrants can be accessed and operated at all times. All valve covers should be kept clear of excavated materials during trench excavation or reinstatement. They must not be buried under stockpile of excavated materials or by road reinstatement. Any construction debris that falls into the valve pits should be cleared immediately.
 - **DON'T expose valves without protection.** Proper fencing with warning signs should be provided to prevent accidental damage to the exposed valves by the swinging parts of the excavators.
 - **DON'T carry out blasting at a distance of less than 6 m from water mains.** This is to avoid causing excessive ground vibration and movement that may exceed the tolerable limits of water mains.
 - **DON'T install services over a water main as far as practicable.**
- 5.4 Photos showing good practices and bad practices of working around existing water mains and of supporting water mains and thrust blocks are attached at [Appendix V](#) for reference.
- 5.5 A “**Flow Chart on Procedures for Safe Working near Water Mains**” is shown in the following page for easy reference.

Flow Chart on Procedures for Safe Working near Water Mains

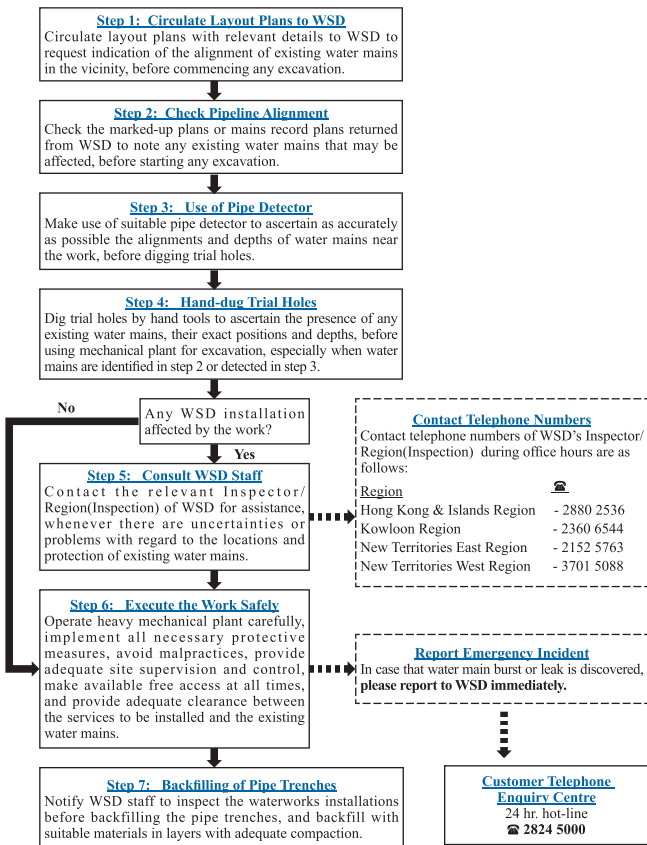

6. Backfilling

6.1 To prevent ground settlements adjacent to or below existing water mains, **all backfills shall be properly deposited and adequately compacted to standards not less than the following:**

- The excavation shall be backfilled with special fill material and fine fill material as defined in the latest edition of the General Specification for Civil Engineering Work (GS) published by the Government of the Hong Kong Special Administrative Region in compacted layers. The backfill materials shall not contain any broken concrete, bricks, clay, bituminous material, materials susceptible to spontaneous combustion, perishable materials or debris, and shall not exceed 75 mm maximum particle size.
- Special fill material around water mains should be **carefully deposited in layers not exceeding 100 mm thick to a level of 300 mm above the crown of the water mains**. The backfill material in this zone shall be carefully compacted by hand-rammers or manually operated power equipment to obtain a relative compaction of at least 85%.
- Fine fill material on top of the 300 mm level shall be deposited in layers of suitable thickness and then compacted adequately with suitable means such as a power rammer or a vibratory plate/compactor.
- In accordance with the requirements of excavation permits, the compacted backfill shall obtain a relative compaction of at least 98% for levels within 200 mm of road formation level and at least 95% for other levels.

6.2 **The contractor should notify WSD staff to inspect the waterworks installations before backfilling of pipe trenches.** Where practicable, WSD would take the opportunity to request the contractor to place a polyethylene identification tape (provided by WSD) on top of the water mains in conjunction with the contractor's backfilling activity. This tape is used to assist in the identification of water mains and to serve as a prior warning to trench diggers of water mains underground.

7. Other Important Points

7.1 Minimum Depth of Water Main

The minimum depths measured vertically to the top of an underground water main are stipulated in the excavation permit issued by HyD (i.e. carriageway – 900 mm from the finished surface of the carriageway; and non-carriageway – 450 mm from the finished surface of the non-carriageway including footway, cycle track, verge, side lane and back lane). However, in areas congested with utilities, some short sections of water mains may have been laid at a shallower depth; and in cases where the carriageway/non-carriageway has been lowered or the non-carriageway has been converted into a carriageway, the existing water mains may be left at a depth less than the minimum requirement.

The minimum cover to a water main should be 700 mm measured from the existing or future sub-grade (i.e. site formation level), whichever is the lower and should always be observed. In case this cannot be achieved, WSD should be consulted to enable suitable measure to be taken.

7.2 Deep Excavation

Deep excavation such as construction of basement can often cause ground movement that may either fracture the pipe body or dislocate/pull out the pipe joints. The ground movement depends on the type of retaining wall, bracing system, construction method, and whether temporary dewatering or lowering of ground water level is involved. Its effect on a water main depends on the magnitude of the differential settlement, the type of pipe material and jointing as well as the age and condition of water main. S, DI, PE and UPVC pipes are flexible, but AC and CI pipes are rigid and brittle. Joints for S pipes (welded/flanged joints), PE pipes (electrofusion joints/butt fusion joints) and UPVC pipes (solvent-cement joints) are however rigid, whereas DI and AC pipe joints (push-in joints) can take up certain amount of differential settlement. In this regard, it is advisable to locate and expose the pipes and joints for an accurate analysis of the likely settlement figures and the limits that the pipes can tolerate. Pipe settlement markers should be installed to gauge the movement of the pipe foundation and be closely monitored. In case the calculations or in-situ measurements indicate an unacceptable settlement level, the water mains should either be diverted if feasible or be supported using mini-piles for instance.

7.3 WSD Inspection Teams

WSD has set up a number of dedicated Inspection Teams since September 1993 as a proactive measure to carry out surveillance of road work activities which may affect water mains and to give advice and/or warning to the concerned contractors for proper protection of water mains against damage.

7.4 Working in the Vicinity of Subways/Underpasses

Contractors should check if the proposed works in the vicinity of waterworks are located in the vicinity of subway(s)/underpass(es) in the presence of water mains that may flood the tunnel or subway in case of water mains burst. If affirmative, carry out an assessment of the impact of water mains burst on the nearby subway(s)/underpass(es) and submit to HyD and WSD for approval before commencement of the works, including the proposed precautionary or mitigating measures to protect the affected water mains/underpass(es)/subway(s) and the public using the facilities.

8. Report Main Burst or Leak Immediately to WSD

In case that main burst or leak is discovered in the vicinity of works, the contractor should report immediately to the Customer Telephone Enquiry Centre of WSD at the 24-hour hot-line (☎ : 2824 5000). WSD emergency gang will attend to the incident immediately.

水管質料
Pipe materials

鋼管 Steel Pipe			球墨鑄鐵管 Ductile Iron Pipe
不銹鋼管 Stainless Steel Pipe			石棉水泥管 Asbestos Cement Pipe
有內搪層鍍鋅鐵管 Lined Galvanised Iron Pipe			無內搪層鍍鋅鐵管 Un-lined Galvanised Iron Pipe
低塑性聚氯乙稀膠管 UPVC Pipe			聚乙烯管 Polyethylene Pipe

附錄二

Appendix II

聯絡電話

(甲) 水務署各分區視察隊督察在辦公時間內的聯絡電話：

<u>分區</u>	<u>負責人員</u>	
香港及離島區	督察 / 香港區 (視察)	2880 2536
九龍區	督察 / 九龍區 (視察)	2360 6544
新界東區	督察 / 新界東區 (視察)	2152 5763
新界西區	督察 / 新界西區 (視察)	3701 5088

(乙) 如遇緊急情況而需於辦公時間外諮詢水務署，可致電客戶電話諮詢中心 24 小時熱線 (☎: **2824 5000**)。

Contact Telephones

(A) List of Contact Telephones of WSD Inspector/Region(Inspection) during office hours:

<u>Region</u>	<u>Responsible Officer</u>	
Hong Kong & Islands	Inspector/HK(Inspection)	2880 2536
Kowloon	Inspector/K(Inspection)	2360 6544
New Territories East	Inspector/NTE(Inspection)	2152 5763
New Territories West	Inspector/NTW(Inspection)	3701 5088

(B) For emergency cases outside office hours in which consultation with WSD is required, contact the WSD Customer Telephone Enquiry Centre 24-hour hot-line (☎: **2824 5000**).

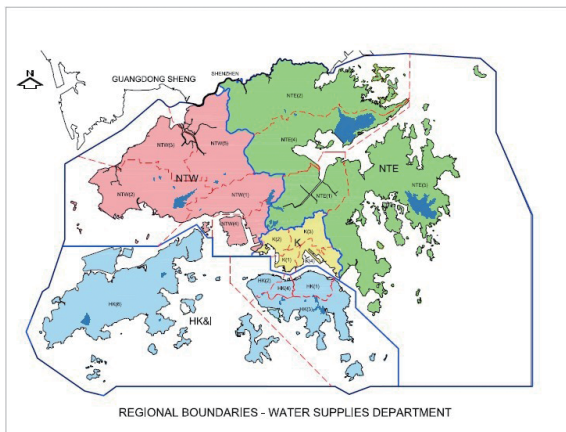

水務署四個分區界線
Boundaries of the four WSD Regions

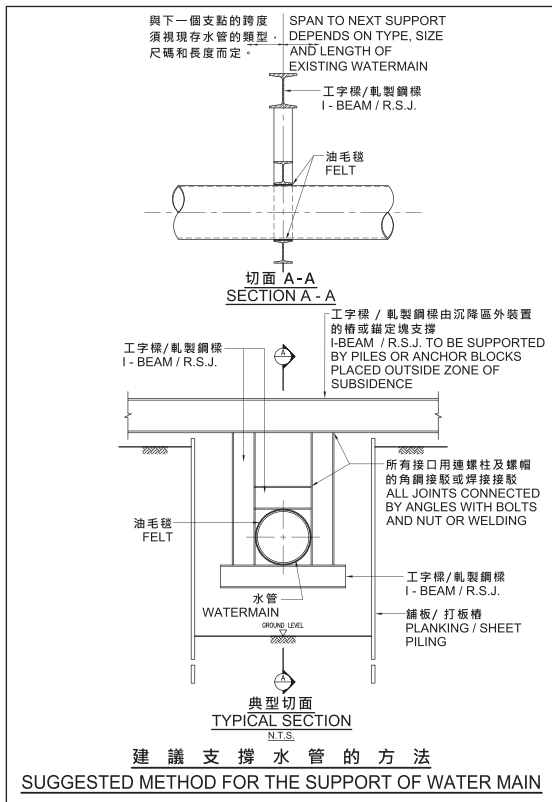

附錄五 (三頁之一)

Appendix V (Sheet 1 of 3)

(甲) 正確保護水管的例子

(A) Examples of **Good Practice** in Protection of Water Main



例一
穩固安全支撐外露水管及混凝土塊。

Example 1
Rigid and secured support to exposed water main and thrust block.



例二
穩固安全支撐外露水管。

Example 2
Rigid and secured support to exposed water main.



例三
穩固安全支撐外露水管。

Example 3
Rigid and secured support to exposed water mains.

附錄五 (三頁之二)

Appendix V (Sheet 2 of 3)

(乙) 不正確保護水管的例子

(B) Examples of **Bad Practice** in Protection of Water Main



例一
大段鑄鐵管和石棉水泥管外露而沒有適當支撐，部分石棉水泥管的混凝土壘被拆毀。

Example 1
Excessively long length of CI and AC mains exposed without providing proper support. Thrust block of AC main partly demolished.



例二
外露水管沒有適當支撐 (不應使用鋼絲繩吊托水管)。

Example 2
No proper support to exposed water main (steel wire ropes should not be used).



例三
外露水管沒有適當支撐 (不應使用尼龍繩吊托水管)。

Example 3
No proper support to exposed water main (nylon ropes should not be used).

附錄五 (三頁之三)

Appendix V (Sheet 3 of 3)

(乙) 不正確保護水管的例子

(B) Examples of **Bad Practice** in Protection of Water Main



例四

在水管上使用重型機械設備挖掘前，沒有先挖掘探洞找出水管位置。

Example 4

No trial hole dug to locate water main, before using heavy mechanical plant to excavate on top of water main.



例五

混凝土墊 (紅色斜線部分) 被非法拆毀，引致水管接口移位和水管爆裂。

Example 5

Concrete thrust block (hatched in red) illegally demolished, resulting in dislocation of pipe joint and main burst.

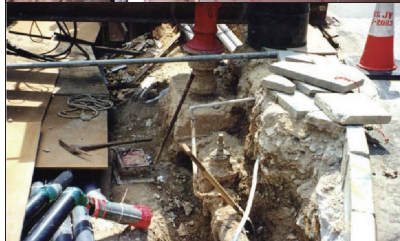

例六

沒有保護外露的水掣。

Example 6

No protection to exposed valve.